

## Catering sink - right hand drainer

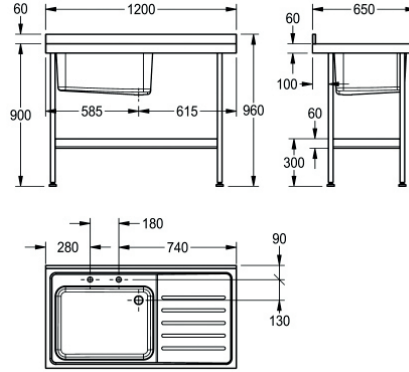

### E20610R

Catering sink

Midi sinks are manufactured from 1.2 mm thick austenitic grade stainless steel descaled finish. All sinks have two tapholes behind each bowl drilled at 180 mm centres. Single bowl sinks are suitable for either 13 mm pillar taps or mixer taps whereas the double bowl sinks are only suitable for pillar taps. Bowls are all supplied with 38 mm waste and standpipe strainer overflow. An earthing lug is fitted under the drainer.

#### Technical data

Bowl height	300mm
Bowl width	610mm
Bowl depth	460mm
Material thickness	1.2mm
Overall depth	650mm
Overall height	900mm
Overall width	1,200mm
Waste hole projection	220mm
Drainer position	Right
Material	Stainless steel
Material code	1.4301 chrome nickel steel V2A
Tailor made	No
Tap ledge	Yes
Type of mounting	Floor mounting
Waste hole position	Right back corner
Bowl finish	Descaled
Rear upstand	Yes
Surface finish	Satin finish
Waste size	DN 40
Drainer or storage	Drainer

Stainless steel underframes complete with shelf are to be ordered as an extra part and are supplied in a flat pack form with easy to read assembly instructions. Each leg is fitted with an adjustable foot (-20, +10 mm) with a working height of 900 mm.