

CATERING SINKS

Model line: CATERING | **E20610L**
Catering sinks | Midi sink

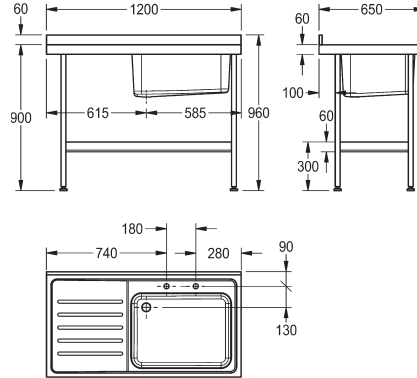

E20610L

Stand and shelf

Midi sinks are manufactured from 1.2 mm thick austenitic grade stainless steel descaled finish. All sinks have two tapholes behind each bowl drilled at 180 mm centres. Single bowl sinks are suitable for either 13 mm pillar taps or mixer taps whereas the double bowl sinks are only suitable for pillar taps. Bowls are all supplied with 38 mm waste and standpipe strainer overflow.

An earthing lug is fitted under the drainer. Stainless steel underframes complete with shelf are to be ordered as an extra part and are supplied in a flat pack form with easy to read assembly instructions. Each leg is fitted with an adjustable foot (-20, +10 mm) with a working height of 900 mm.

Technical data

Material	Stainless steel
Material thickness	1.2mm
Surface finish	Satin finish
Overall dimensions	1200 x 900 x 650mm
Overall bowl dimensions	610 x 300 x 460mm
Type of mounting	Floor standing
Waste hole projection	220mm
Drainer position	Left
Type of mounting	Floor standing
Tap ledge	Yes
Waste hole position	Left back corner
Bowl finish	Satin finish
Rear upstand	Yes
Waste size	DN40
Drainer or storage	Drainer
Net weight	16.2kg