



E206 10R & K2067 1N

Datasheet
Cleaning instructions
Product guarantees

Catering sink

MODEL RANGE: | E20610R | 214.0000.040

Catering sinks | Catering sinks

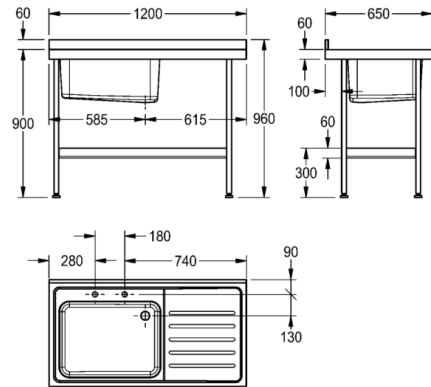

Midi sinks are manufactured from 1.2 mm thick austenitic grade stainless steel descaled finish. All sinks have two tapholes behind each bowl drilled at 180 mm centres. Single bowl sinks are suitable for either 13 mm pillar taps or mixer taps whereas the double bowl sinks are only suitable for pillar taps. Bowls are all supplied with 38 mm waste and standpipe strainer overflow. An earthing lug is fitted under the drainer. Stainless steel underframes complete with shelf are to be ordered as an extra part and are supplied in a flat pack form with easy to read assembly instructions. Each leg is fitted with an adjustable foot (-20, +10 mm) with a working height of 900 mm.

Single bowl, RH single drainer

Technical data

Bowl height	300.00 mm
Bowl width	610.00 mm
Bowl depth	460.00 mm
Material thickness	1.20 mm
Overall depth	650.00 mm
Overall height	900.00 mm
Overall width	1,200.00 mm
Waste hole projection	220.00 mm
Drainer position	Right
Material	Stainless steel
Material code	1.4301 Chrome Nickel steel V2A
Tailor made	No
Tap ledge	Yes
Type of mounting	Floor mounting
Waste hole position	Right back corner
Bowl finish	Descaled
Rear upstand	Yes
Surface finish	Satin finished
Waste size	DN 40
Drainer or storage	Drainer
Product code	214.0000.040

Catering sink

MODEL RANGE: | E20610R | 214.0000.040

Catering sinks | Catering sinks

Accessory Mandatory



2000100525

K20671N

Accessory Optional



208.0574.189

F1081N



208.0574.185

F1083N



208.0574.187

F1074N



208.0574.211

F1330N



208.0576.821

F1075N



2000100425

F1062

K2067 1N Underframe

MODEL RANGE: | K2067 1N |

Catering sinks | Complementary parts



Stand and shelf

Technical data	
Material thickness	1.20 mm
Overall depth	450.00 mm
Overall height	50.00 mm
Overall width	1,050.00 mm
Material	Stainless steel
Material code	1.4301 Chrome Nickel steel V2A
Tailor made	No
Type of mounting	No mounting
Surface finish	Satin finished
Product code	214.0000.187

Cleaning and Care of Stainless Steel

All products made from Stainless Steel thrive from frequent cleaning and unlike other materials, it is impossible to "wear out" from excessive cleaning.

Stainless Steel, like any surface exposed to the environment gets dirty from a variety of contaminants. These contaminants come from many sources ranging from grease, oil, bleach or just everyday use.

Any contaminant must be cleaned from the product immediately, especially after installation, with warm soapy water and applied with cloths made of a natural or artificial fibre, chamois leather, absorbant cloth, sponge or brushes with a natural or plastic bristle. All stainless steel surfaces should be cleaned on a regular basis.

Steel wool, scouring pads, scouring powder or sandpaper should **NOT** be used on Stainless Steel as these can scratch and damage the material.

If the product is covered in a protective film, this should be removed immediately as the action of heat and light can cause it to stick to the surface and make it difficult to remove at a later date.

Providing that the stainless steel products are cleaned and maintained regularly, using the correct cleaning materials, the product should last the life of the building into which they are installed.

Products not to be used on Stainless Steel

Bleach

Abrasive Sponge Pads

Abrasive Cleaning Creams

Steel Wool

Wire Brushes

Solutions containing Chloride

TERMS & CONDITIONS OF SALE

1. General

All quotations issued and orders received are subject to these Conditions of Sales and no alterations shall take effect unless confirmed in writing by Franke Sissons Limited, (hereinafter referred to as "the Seller" or "Franke"). No terms, condition or warranty not recorded herein shall be binding on the Seller, except where such is necessarily imported into the contract under any Statute or at Common Law.

2. Prices

(i) Errors and omissions are subject to correction
(ii) Unless otherwise stated in writing, prices charged would be those ruling at the date of the order being received by the company.
(iii) Unless otherwise specified, prices include for the supply and delivery only of the goods but not for their off-loading, positioning and installation.
(iv) All prices shown are subject to VAT at the standard rate. Prices are correct at the time of printing but are subject to alteration without prior notification.

3. Payment

(i) In respect of an initial order and whenever else specified by the Seller, the Buyer shall pay the Seller in full as a condition precedent to despatching the goods. In all other cases, payment must be made in full by no later than 30 days from the date of the invoice.
(ii) Where payment is not received by the due date, the Seller reserves the right to charge interest on outstanding amounts for each month or part of any month that payment is overdue, at the rate of 1½ per cent per month, or part thereof, and/or at the Seller's option to suspend all deliveries of all goods to the Buyer.
(iii) Should the Seller be prevented by the Buyer from effecting delivery on the due date, the full price of the goods shall become payable as if the goods had been delivered.

4. Delivery

(i) Any time expressed for delivery shall be deemed to be an estimate only, time not being of the essence for the contract unless separately agreed to in writing by the Seller. The Seller accepts no liability for any loss sustained by the Buyer through late delivery and further where a time for delivery has been agreed but delivery is delayed for any reason beyond the control of the Seller, a reasonable extension of time shall be allowed to the Seller.
(ii) Where working drawings have to be approved by either the Buyer or his agent then the estimated delivery period is to be applied from the date of receipt in writing by the Seller of this approval.
(iii) Where a time for delivery is agreed and the Buyer fails for whatever reason to accept the delivery, a minimum charge of £25 will be incurred and the Seller reserves the right to make a reasonable charge for storage. Should delivery not be possible after one week's delay the Seller shall be entitled to submit his invoice and the normal conditions of payment will apply.
(iv) The Buyer shall provide adequate labour and unloading facilities at the place of delivery at his own risk and expense.
(v) If advance notice of the approximate arrival time of the delivery vehicle is required this must be stated on the order.
(vi) An additional charge will normally be made for packing and delivery outside the mainland of the United Kingdom.
(vii) Any special delivery arrangements by passenger train, carriers or similar requests by the Buyer will be charged at cost.

Delivery Charges

UK Mainland and Northern Ireland –

Composite Units – POA

All other items:

-Small Package (max. 1metre on any one side and up to 25kg) @

£5.50

-Medium Package (max. 1.5metre on any one side and up to 25kg) @

£15.00

-Pallet @ £55.00

Republic of Ireland –

Composite Units – POA

All other items:

-Small Package (max. 1metre on any one side and up to 25kg) @

£10.50

-Medium Package (max. 1.5metre on any one side) @ £30.00

-Pallet @ £80.00

Channel Islands and Scottish Islands - POA

Special Deliveries –

The Seller reserves the right to charge as necessary for special or timed deliveries (including Saturdays), made at the request of the Buyer. Deliveries that cannot be completed due to the fault of the Buyer will be chargeable.

5. Restocking Charges

(i) Only products that meet the following criteria, will be considered for return by prior agreement
- Less than 30 days old (from invoice date)
- In its original packaging
- In a resalable condition
- A current product shown in the latest published copy of our sales catalogue
(ii) A restocking charge of 35% of the original invoice value will be applied.
(iii) Any goods authorised for restocking must be returned at the Buyer's expense and risk. Any goods received back damaged will not be credited.
(iv) An Authorisation to return goods form needs to be issued by the Seller before any goods will be accepted. The Seller reserves the right to refuse a restocking request.
(v) **Non-standard products will not be accepted for return.**

6. Cancellation of Order

(i) Special item orders cannot be cancelled. The Seller will invoice the full amount whether or not the product is still required.
(ii) Once goods have been delivered, they are not returnable, under any circumstances without the Seller's agreement in writing.

7. Damage or Loss in Transit

(i) The Seller's responsibility ends with the arrival of goods at the designated delivery point. The Seller is not liable for any damage or loss during unloading or thereafter.
(ii) The Buyer or his agent should examine goods on arrival and details of any damage or loss entered on the Carrier's note.
(iii) In the event of non-arrival, damage or shortage of goods, no claim will be accepted unless notification is given to the Seller in writing within 7 days from the date of the Seller's invoice.
(iv) Damaged goods will not be replaced or repaired if they have been used or installed.

8. Property and Risk

(i) Title to each item of the goods supplied by the Seller remains vested in the Seller until the purchase price and all other monies owing by the Buyer in relation to those goods or the price (whether or not due) are paid in full.
(ii) In addition, and without prejudice to sub-condition (i) above, title to goods supplied by the Seller remains vested in the Seller until such time as there are no monies owing by the Buyer to the Seller on any account (whether or not due).
(iii) Notwithstanding this reservation of title the Buyer may resell any goods in the ordinary course of business which remains the property of the Seller, in which event the Buyer shall remit the proceeds of sale to the Seller and in such a way that they are kept separate and are readily identifiable.
(iv) The Seller shall be entitled (but not obliged) at any time to recover and dispose of any goods to which it has retained title under this clause and the Buyer will be deemed to have granted to the Seller an irrevocable licence, for so long as any monies shall remain owing to the Seller to enter the Buyer's premises to inspect and recover any such goods.
(v) The Buyer agrees to undertake in respect of all goods that remain the property of the Seller:
(a) To store the same in such a way that they are readily identifiable as the property of the Seller.
(b) To insure the same to their full value.
(c) To hold the same in all respects as bailee for the Seller.
(vi) Where the property in the goods has not passed, the Seller may nevertheless maintain an action against the Buyer for the purchase price and all other monies then owing to the Company in relation to the goods notwithstanding Section 49 of the Sales of Goods Act 1979.
(vii) If the Seller repossesses or resells its goods it shall credit the Buyer in the Seller's accounts (in each case after deduction of all expenses of recovery and/or sale) with the lesser of (i) the net value or proceeds of sale (as the Seller may elect) of the goods and (ii) the invoiced price (excluding value added tax) to the Buyer of the goods.
(viii) Notwithstanding the provisions of Condition 8(i) and 8(ii) above the goods shall be at the risk of the Buyer from the time when they are tendered for the delivery at an agreed destination or are available for collection by the Buyer or cease to be in the Seller's possession and in particular when they are delivered into the possession or custody of a carrier, forwarding agent, warehouseman or other bailee or agent for the purposes of transmission whether or not such person contracts with or is instructed by the Seller or Buyer.

9. Drawings

All drawings by the Seller shall remain the Seller's property and copyright, and therefore must not be wholly or partially used or copied without the Seller's written permission.

10. Description

Illustrations and dimensions, in the Seller's catalogue or documents, although correct in general detail, do not constitute a sale by description. The Seller's policy is one of continuing improvement and the Seller reserves the right to vary or modify the design, specification, or surface finish without notice, unless written undertaking has been given to the contrary.

11. Replacement

Where the goods supplied by the Seller are of the Seller's design and manufacture the Seller will make good any defects in those goods subject to the following conditions:-
(i) The Buyer shall notify the Seller in writing at the Seller's address, Franke Sissons Ltd, 14 Napier Court, Gander Lane, Barborough Link Business Park, Barborough S43 4PZ within 7 days of the date of delivery.
(ii) The Seller shall be provided with an adequate opportunity to examine the goods.
(iii) The Seller shall not be obliged to replace any goods or make any allowances or other arrangement if, in the reasonable opinion of the Seller, the defect has arisen from accident, misuse, neglect, installation, lack of reasonable maintenance, or any other cause beyond the reasonable control of the Seller.
(iv) Where the defect is reasonably attributed to the fault of the Seller, the Seller shall replace or repair the defective goods, but shall not be liable for any costs of removal of the defective goods, or installation of replacement goods, nor any consequential loss or damage arising therefrom.
(v) The Seller will not accept any charges for remedial work that is carried out without his express authority and approval.
(vi) The Seller's liability shall be limited to the repair or replacement of materials and components manufactured by the Seller. No goods are guaranteed by the Seller for any specific length of time but are warranted to be free from defect in workmanship and materials at time of delivery. No liability can be accepted in respect of products that have become defective due to contact with corrosive liquids such as strong bleaching solutions and fluids, photographic developing liquids, immersion type silver cleaning fluids and the like that are injurious to stainless steel.
(vii) Where goods and components supplied by the Seller are not of the Seller's design and manufacture, the Seller's liability shall be limited to the guarantee provided by the manufacturer of such goods and components.
(viii) The Seller shall not be under any duty arising from Section 11 of these Conditions of Sale if the Buyer is in breach of any provision of the Contract with the Seller until the Buyer has remedied the breach.

12. Indemnity

The Buyer shall indemnify the Seller against all damages, penalties, costs and expenses to which the Seller may be liable if any work done in accordance with the Buyer's specification infringes any third party property right.

13. Information

(i) All warning data sheets, diagrams and other information as to the construction, assembly use, storage or disposal of the goods made available to the Buyer before, at the time of, or after the time of supply of the goods to the Buyer shall be supplied by the Buyer to any person to whom the Buyer supplies the goods or any product in which the goods are incorporated and the Buyer shall impose a similar requirement on such person. The Buyer shall indemnify the Seller in full against all liabilities costs claims demands and expenses resulting from any failure by any person other than the Seller to make such warnings data sheets, diagrams and other information available to any other person.
(ii) Where an indication as to time limits for the use of the goods has been supplied to the Buyer shall procure that all persons into whose hands the goods may come are aware of such time limits and shall not supply the goods after such time limits have been exceeded. (iii) The Buyer will notify the Seller of any intended application of the goods other than that contemplated in the information referred to in sub-section (i) above so as to enable the Seller to verify that the goods will be safe for use in such application.

14. Termination

If the Buyer commits any breach of these conditions, or if in the opinion of the Seller, the financial standing of the Buyer becomes unsatisfactory, the Seller may, without prejudice to its other rights and remedies, terminate this contract and any other contract with the Buyer. The Seller shall also be entitled to require immediate payments for all goods delivered. In the event of termination under the provisions of this clause the Seller shall be relieved of all liability under this contract and any other contract so terminated.

15. Force Majeure

In the event of war, invasion, act of foreign enemy, hostility (whether war has been declared or not), civil war, rebellion, revolution, insurrection or military or usurped powers, the Seller shall be relieved of liabilities incurred under the contract whatsoever and to the extent to which fulfilment of such obligations is presented, frustrated or impeded as a consequence of any such events or by status, rules, regulations, order or requisition issued by any Government Department, Council, or duly constituted authority, or from strikes, lock-outs, breakdown of plant or any other causes (whether or not like nature) beyond the Seller's control.

16. Law and Arbitration

(i) All contracts entered into by the Seller shall be subject to English Law.
(ii) In the event of any dispute between the parties the same shall be submitted to an appropriate arbitrator selected by the Seller.

17. General

(i) Any notice to be given under these conditions may be delivered by hand, or sent by first class post, addressed to the party to be served at its registered office for the time being or (if not a company) the address for the party giving the notice. Notices served by post shall (except where expressly provided otherwise) be deemed served on the second business day after the date of posting, 'business day' shall mean a day other than a Saturday or Sunday or an English Bank or Statutory Public Holiday.
(ii) No failure or delay by the Seller in exercising any of its rights under this contract shall operate as a waiver thereof.
(iii) In the event that any of these conditions shall become or shall be declared by any court of competent jurisdiction to be invalid or unenforceable in any way, such invalidity or unenforceability shall in no way impair or affect any of the other conditions hereof all of which shall remain in full force and effect.
(iv) Clause headings are for ease of reference only and do not affect construction.

18. Warranty

(i) The Seller's products have the following warranty:
Stainless steel – 5 years
Miranit – 5 years
Brassware and water controls – 2 years
Glass reinforced plastic (GRP) urinals – 3 years
Hand dryers – 1-3 years depending on model

Warranty is from the date of supply by the Seller, against faulty workmanship in the manufacture and for products placed and used under normal conditions.

19. Payment Methods

Payment can be made by BACS transfer, cheque, debit or credit card. Any re-presented or dishonoured cheque will be charged an administration fee of £10.

20. Retention of Title

All goods delivered by the company will remain the company's property until all debts owed to the company by the buyer, including any balances existing are settled.

21. Internet Resellers Policy

Anyone wishing to resell the Seller's products on the internet whether buying direct from the Seller or not, must sign the Seller's Internet Partner Agreement provided by the Seller in order to resell those Products. The Seller has the ultimate decision on approved resellers.

22. Data Protection and Processing

(i) Personal data is any information relating to an identified or identifiable natural person ('Data Subject') as defined in the applicable Data Protection law.
(ii) Personal data will be gathered, processed and used by Franke in compliance with the applicable Data Protection law and all of our employees, Franke Group companies and third party service providers who have access to personal data are obliged to respect the confidentiality of the personal data.
(iii) In the event that Franke is provided with and receives personal data via the Buyer or a point of sale for such purpose described above, Franke is an independent controller under applicable data protection law.
(iv) Franke collects personal data when the Buyer submits it to us, through registration, completion of forms or e-mails, as part of an order for products or services, after-sale support for products or services, inquiries or requests about products being ordered and similar situations in which the data subject has chosen to provide the information to Franke or via a point of sale to Franke.
(v) Some personal data provided (name, address, phone number and email address) will be processed by Franke for marketing, advertising or promoting purposes. We assume that this is of mutual interest for our Buyer and for the Data Subject to maintain a good business relationship and the respective Data Subject can object to the processing of his/her data for this purpose at any time without giving reasons by contacting Franke.
(vi) Some of the personal data provided may be stored or processed in other jurisdictions, such as the United States, whose Data Protection laws may differ from this jurisdiction. In such cases, Franke ensures that appropriate protections are in place to require the data processor in that country to maintain protections on the personal data that are equivalent to those that apply in the country of Franke.
(vii) The Buyer is obliged to inform any point of sale and its end-users that it complies with applicable Data Protection law and personal data will be processed by Franke according to the terms and limitation set forth in this Clause. The Buyer shall, without limitation, defend, hold harmless and indemnify Franke in the event of damage that is attributable to the Buyer's transferring of personal data or in breach of applicable Data Protection law.
(viii) Our full privacy statement can be found on our website: www.franke.com.

NORTHERN OFFICE

Franke Water Systems
14 Napier Court
Gander Lane
Barlborough
S43 4PZ
Phone +44 (0)1246 458900
ws-info.uk@franke.com
www.franke.co.uk

SOUTHERN OFFICE

Dart Valley Systems
Kemings Close
Long Road
Paignton, Devon
TQ4 7TW
Phone +44 (0) 1803 529021
sales@dartvalley.co.uk
www.dartvalley.co.uk

