

# DRINKING FOUNTAIN: ANMX306

ANMX306 | 2000100304

ARTICLE GROUP : **ANMX306** | ARTICLE FAMILY : **Drinking fountains unchilled** | PRODUCT GROUP : **Water dispensers**

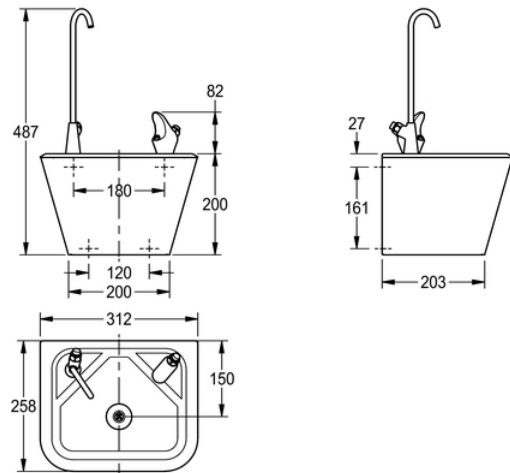

The wall hung Drinking Fountain with bottle filler is ideal for schools and colleges where the drinking of water has been shown to improve levels of concentration in students and increase academic achievement. The compact drinking fountain incorporates a water bubbler and a bottle filler to save space in busy corridors and washrooms. Drinking water fountains are manufactured from grade 304 stainless steel, material thickness 1.2mm, supplied complete 19mm waste and water bubbler tap. The wall mounted model is simply fixed to the wall using a joggle strip and integral mounting brackets.

## TECHNICAL DATA

bowl - bowl depth	20.00 mm
bowl - depth	256.00 mm
bowl - width	210.00 mm
gross weight	3.60 kg
material	stainless steel
material code	1.4301 Chrome Nickel steel V2A
material thickness	1.20 mm
net weight	3.20 kg
overall depth	258.00 mm
overall height	200.00 mm
overall width	310.00 mm
surface finish	satin finished
type of mounting	wall mounting
type of operation	manual operation
waste hole position	centre
waste hole projection	153.00 mm
waste size	DN 20