

DUH hospital disposal unit

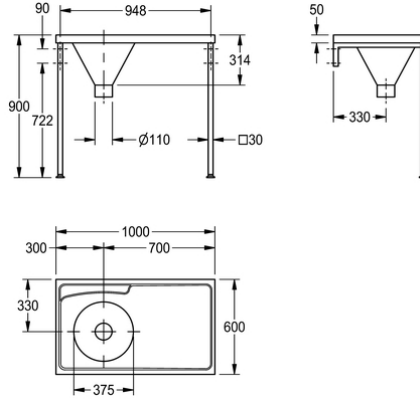

G22016R

Hospital disposal unit

A DUH hospital disposal unit manufactured from 1.2mm thick, grade 1.4301 (304) stainless steel with a satin polish finish. The top is turned down on all four edges and incorporates a wet area recess. Fitted with a sluice hopper at one end, the hopper has a 110mm dia. outlet which can accept a P or S trap, available as an extra. 9 litre capacity plastic cistern with plastic downpipe is available, these are fitted with a 13mm HP brass valve, plastic float and CP metal flushing lever handles.

The unit should only be fed from a cistern or tank water supply. L or R after the code number refers to the handing of the drainer i.e. left or right when facing front of unit. Unit can be mounted on either stainless steel cantilever brackets or Front leg supports give a working height of 900mm and have adjustable feet which can be screwed to the floor for extra stability.

Technical data

Bowl - bowl depth	300mm
Bowl finish	Satin finish
Bowl width	375mm
Drainer position	Right
Drainer or storage	Drainer
Gross weight	12.5kg
Material	Stainless steel
Material code	1.4301 chrome nickel steel
Material thickness	1.2mm
Minimum flushing capacity	6 litre
Outlet size	DN 100
Overall depth	600mm
Overall height	300mm
Overall width	1,000mm
Surface finish	Satin finished
Type of mounting	Wall and floor mounting
Net weight	11.3kg