

Model A washbasin

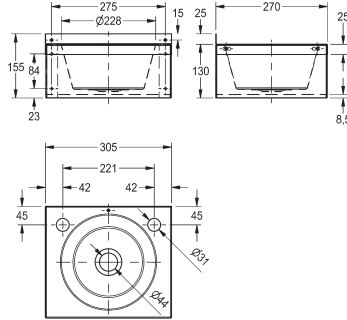

D20161N

Model A washbasin - wall mounted

Model a 240mm diameter wall mounted washbasin with apron. Manufactured from 0.9mm thick grade 1.4301 (304) stainless steel with a high polished finish. The basin is prepared for 32mm waste outlet and is supplied with two tap holes in the rear ledge, without an overflow. The basin is wall mounted using the fixing holes provided in both the rear up-stand and the rear apron fixing brackets for extra security. Screws and plugs are not supplied.

Technical data

Bowl - bowl depth	125mm
Bowl finish	Satin finish
Bowl depth	240mm
Bowl shape	Circle
Gross weight	2.2kg
Material	Stainless steel
Material code	1.4301 chrome nickel steel
Material thickness	0.9mm
Overall depth	290mm
Overall height	157mm
Overall width	290mm
Overflow	No
Rear upstand	Yes
Splash back	Yes
Surface finish	Satin finish
Tap ledge	Yes
Type of mounting	Wall mounting
Waste hole position	Centre
Waste hole projection	145mm
Waste kit included	Yes
Waste size	DN 32
Net weight	1.8kg

Model A washbasin

Optional accessories



Optional accessories

F1080N

Crosshead basin taps

Optional accessories

F1329N

Lever action basin taps
