

# JUMBO ROLL HOLDER: CHRX670

CHRX670 | 2000057141

ARTICLE GROUP : **CHRX670** | ARTICLE FAMILY : **WC-roll holders** | PRODUCT GROUP : **Accessories**

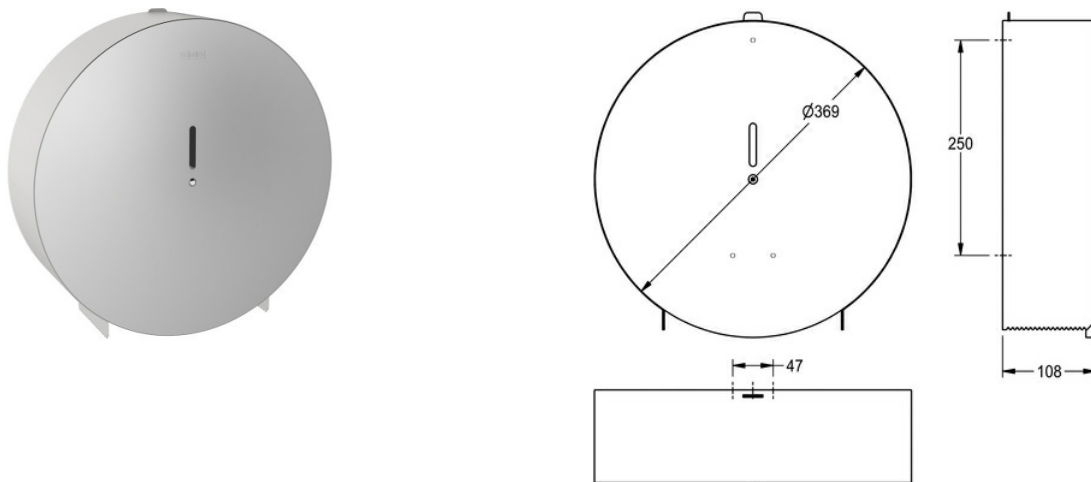

Jumbo roll holder for wall mounting, stainless steel, surface satin finished, material thickness 0.9 mm, closed round casing with inspection window, paper withdrawal over two tear-off edges, locked with hexagonal allen screw, for 1 roll with max. Ø 350 mm, incl. stainless steel screws, dowels and hexagonal allen key.

## TECHNICAL DATA

maximum depth/diameter of consumable	350.00 mm
maximum width of consumable	100.00 mm
filling quantity	1 rolls
gross weight	2.42 kg
lock	screw-lock
material	stainless steel
material code	1.4301 Chrome Nickel steel V2A
material thickness	0.90 mm
net weight	1.90 kg
overall depth	108.00 mm
overall height	369.00 mm
overall width	369.00 mm
spindle	yes
surface finish	satin finished
type of fixing	screw
type of mounting	wall mounting