

Fault Finding

Programmable Sensors - AC02-017/AC02-021/AC02-023

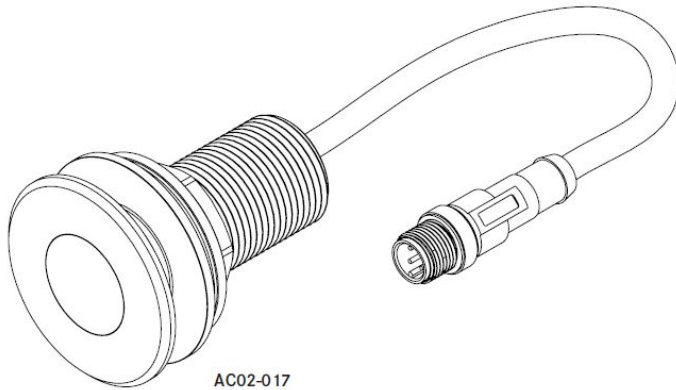

NOTE. Direct sunlight and reflective surfaces will affect the performance of the IR sensor. Please consider this when designing your washroom.

- **Solenoid valve running continually (full bore) when water is turned on**
 - The solenoid valves are latching and can be supplied either open or closed. Powering up the sensor will send a signal for the valve to close.
 - The sensors require a calibration time of 20 seconds once the power is turned on. Do not try to operate the taps during this period.
- **Solenoid valve working, but letting by or dripping.**
 - Pipe debris may have entered the solenoid valve, preventing the diaphragm from closing. Clean out the solenoid referring to the solenoid cleaning instructions found on our website - <https://dartvalley.co.uk/products/accessories/6v-dc-asco-valve-scxh210g202bw-12-7mm-orifice-0-35-10-bar-15mm-2/>
- **Sensor not functioning at all**
 - Check power supply at spur.
 - If battery powered, check battery voltage is 6v or above. Replace if required.
 - Check all cables for loose connections. Make sure all plugs are correctly connected and in the right orientation. Refer to Programmable Sensor instructions for details. <https://dartvalley.co.uk/wp-content/plugins/download-attachments/includes/download.php?id=2582>
 - Check pressure rating of the solenoid valve is suitable for the site pressures. High and low pressure valves are available. Low pressure valves may lock out if the site pressure is greater than that rated on the valve. An alternative valve may be required.
 - Use Handheld Programmer (AC01-001) to check sensor settings are correct.

- **Sensor will turn on and off on its own accord.**
 - Check for mirrors or reflective surfaces in direct line of sight of the sensor. Remove from line of sight if possible. Note: Another sensor directly opposite will cause a similar issue.
 - Sensing range may need reduced to stop false triggering. This can be done with the Handheld Programmer (AC01-001)
 - Please note taps with red or blue sensor lenses are NOT compatible with the handheld programmer.
- **Sensor not working as required for selected function - i.e. Urinal, Shower, Tap etc.**
 - Using the Handheld Programmer (AC01-001) Read the sensor as per instructions to check sensor is in the correct mode for the required function. Change function if required.
<https://dartvalley.co.uk/wp-content/plugins/download-attachments/includes/download.php?id=6930>

If none of the recommendations above resolve the problem, please contact technical Support on:
01803 529021 or email: techsupport@dartvalley.co.uk