

DVS POWER PACK

WC00-155

The DVS Power Pack is designed to power an array of DVS products direct from its battery.

An onboard Intelligent Charger keeps the battery at an optimum charge level. In the event of a power out, the battery will continue to supply power for up to 10 days depending on load.

PRODUCT NUMBER

WC00-155

TECHNICAL DATA

Control Box:

Weight	1.45 kg
Material	ABS Plastic
Power source	Mains Spur
IP rating	65
Amps	200 mA (MAX)
Voltage	6.9V DC

Compatible With;

DVS Battery Operated WC Flushvalve (Low Voltage Mains)

DVS Tap Control System

DVS No-Touch Taps

DVS Programmable Sensor

DVS Battery operated showers with Programmable sensors

Please contact DVS for any required compatibility advice.

ADDITIONAL INFORMATION

For Installation & Set-Up information, please see - WC00-155 Instructions.

Available on www.dartvalley.co.uk

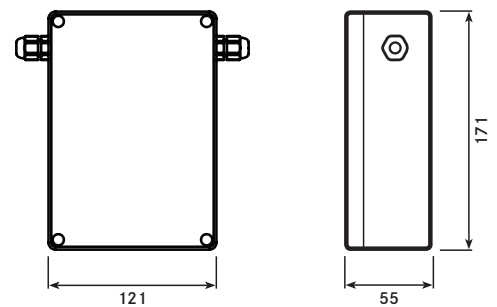

ALL DIMENSIONS IN MM

2021-06-17, Dart Valley Systems