

## Installation steps:

1. Fill the soap bottle with liquid soap for the first use.
2. Press and hold button until liquid soap is dispensed from the nozzle.
3. Place hand below the nozzle to dispense liquid soap into palm of hand.

The soap dispensers have 4 settings to adjust dispense of soap, the first gear being the least volume and the fourth being maximum. Factory default is set at second gear.

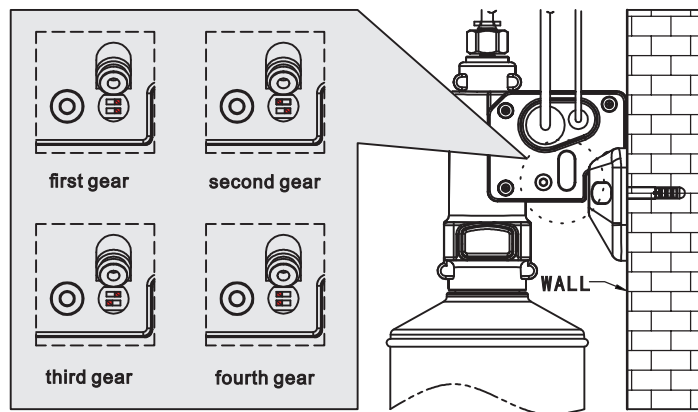

## CARE AND MAINTENANCE

If the soap dispenser fails to function correctly, firstly check all connections are tight and free from air leaks. If dispenser still fails to function, place manifold into a bottle of warm water. Pump the warm water through the dispenser to dislodge any dried soap residue and then refit manifold into soap bottle.

Water marks and soap residue on polished chrome surfaces are best cleaned using warm water and a mild detergent. Use a stainless steel cleaner for brushed stainless steel soap dispensers. Never use an abrasive cloth to remove stubborn stains. Dry with a soft clean cloth.

# KWC DVS

Automatic Soap Dispenser

## INSTRUCTIONS

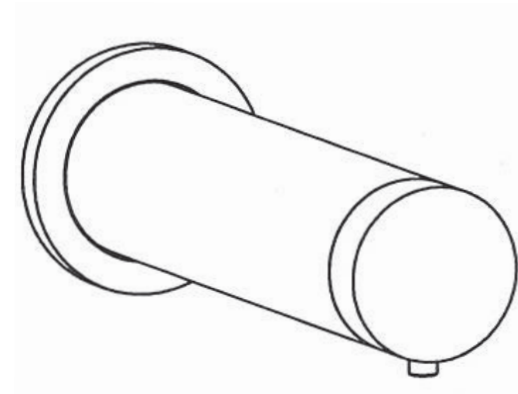

09062021

## Specifications:

Model No.	SD01-001-005
Material	Brass
Power Supply	AC: 220V
	DC: 6V (4xAA)
Bottle Capacity	1.6-2L
Ambient Temp.	Normal Temperature
Sensor Range	15±3cm
Viscosity	100-3500cp (mpA · s)
Soap Volume	≤2mL/times(four gears)

## Installation:

Note : The soap dispenser should not be installed close enough to a basin so that it is within its maximum range.

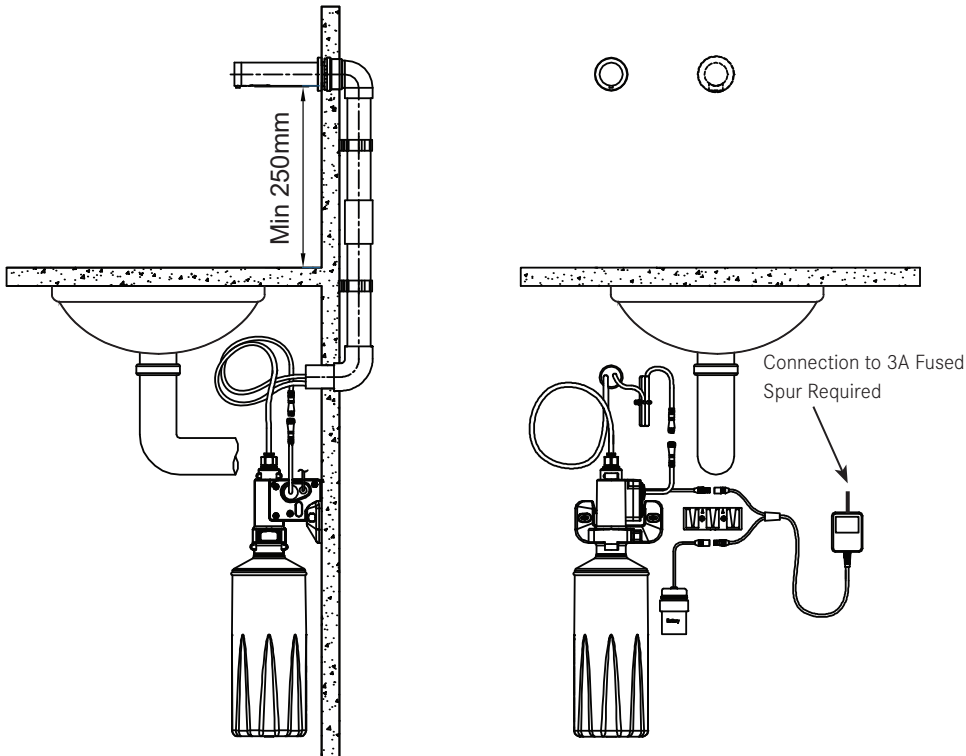

## Roughing in:

