

Fault Finding

1. VALVE WILL NOT OPEN OR CLOSE PROPERLY

- Check valve supplied is suitable for the on site pressure, if in doubt contact DVS for advice.
- The solenoid valve has a flow direction, ensure it is the right way round
- There maybe debris in the solenoid valve. Remove valve and flush under running tap, refit and test.

2. SENSOR CONTROL WILL DO NOTHING

- If possible check voltage from battery or PSU (6 volt DC required)
- Control board may have locked up. With power connected press reset and try again (do not hold reset down).
- Check fuse on control board. If blown, contact DVS for a replacement.

3. VALVE OPENS AND RUNS FOR A LONG PERIOD BEFORE SHUTTING OFF

- Check wiring to the plug on solenoid, it may be wired the wrong way round, reverse wires if necessary.
- Make sure all connections are correct and tight.

Warranty, Support & End of Life Disposal

Warranty

The Flushmatic Urinal Flush Controller is guaranteed for 5 years from purchase against defective material and assembly. Any third party manufacturers products hold their own warranty.

Disposal of Electrical / Electronic Equipment and Batteries



The use of this crossed out wheeled bin logo indicates that this product needs to be disposed of separately to any other household waste.



Within each of the European Union member countries, provisions have been made for the collection and recycling of waste batteries, unwanted electrical and electronic equipment. Outside of the EU it will be necessary to dispose of this product at your local community waste collection or recycling centre.

To help preserve our environment we ask that you dispose of this product correctly. Please contact your local council for collection centre details.

KWC DVS

Flushmatic Urinal Flush Controller Installation & Operating Instructions

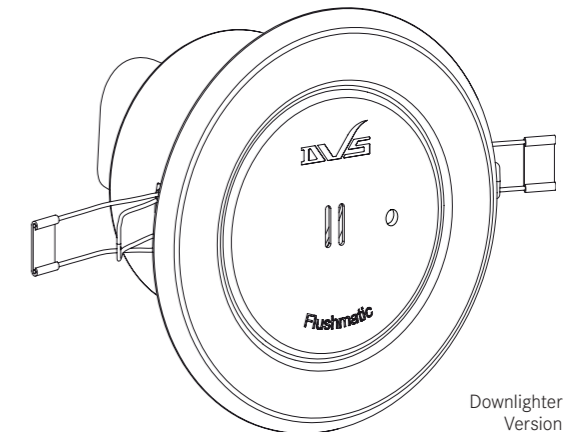
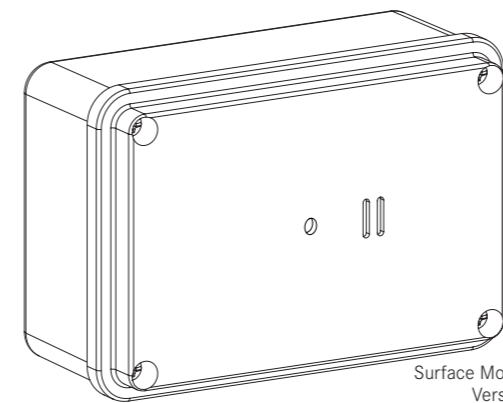

Step 1 : Safety First

These instructions relate to the use of the Flushmatic Urinal Flush Controller only, any external or 'add-on' parts will be supplied with separate instructions.

It is recommended that the mains electrical part of the installation be carried out by a qualified electrician in accordance with the latest electrical regulations. It is also recommended that any plumbing is carried out by a qualified plumber.

This is an electronic device which must be installed as per these instructions to perform correctly.

Prior to drilling any holes, please check the on-site asbestos register.

IMPORTANT : Please read these instructions carefully and follow each stage in order!



Step 2 : Parts

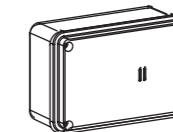

Surface Mount Version

or

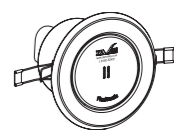

Downlighter version

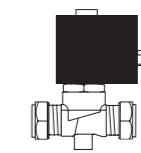

Solenoid Valve (AC17-002)

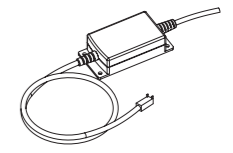

Optional 6-volt DC DVS Power Supply



Lithium Battery- for Downlighter Version (AT00-026)

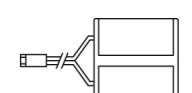

Lithium Battery- for Surface Mount Version (UC00-006)

Requires 0.5mm 2 Core Flex Cable (Not Supplied)

KWC DVS | Northern office, 14 Napier Court, Barlborough, S43 4PZ, 01246 458900 | Southern office, Kemmings Close, Paignton, TQ4 7TW, 01803 529021
kwcdvsales@kwc.com | www.dartvalley.co.uk

Step 3 : Plumbing & Positioning the Sensor

Fitting the Solenoid Valve

It is highly recommended that a water filter (not supplied) be fitted prior to the solenoid valve to ensure reliable operation.

Turn off the local water supply and position the solenoid valve as near to the cistern as possible, and preferably upright (as shown in Fig 2). Cut the supply pipe and purge any debris or swarf. Fit Solenoid valve ensuring correct flow direction and joints are tightened check for leaks. In the event of very low or high water pressure DVS can offer alternative solenoid valves.

NOTE : The numbers on the valve body indicate flow direction. 1 = Inlet/2 = Outlet

The system works by a timed fill and auto flush, all adjustments to water flow after the solenoid valve should be removed.

Note: If solenoid valve is in open position, this can be closed, once installation is complete. See Step 6 - Cistern Fill Time Using Button.

Positioning the Sensor

The sensor should, ideally be fitted to the ceiling above the urinal, so that people moving to the urinals must enter/cross the detection area (shown in Fig 3).

The sensor box should be located in a dry location, away from any extremes of temperature and not exposed to dirt, dust or damp. The unit should be accessible when required but not within easy reach of unauthorised persons.

You must avoid locating the Sensor near heat sources, for example; radiators, hot pipes, etc or where direct sunlight may fall upon

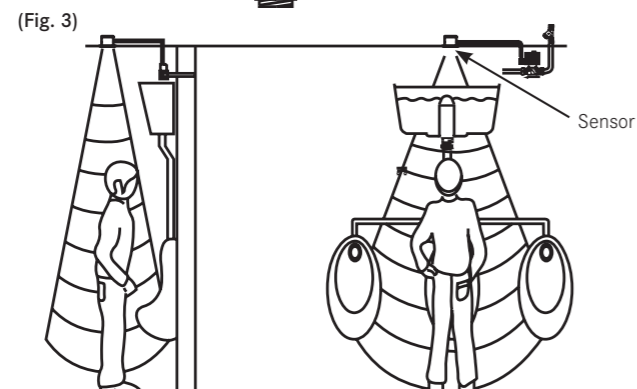
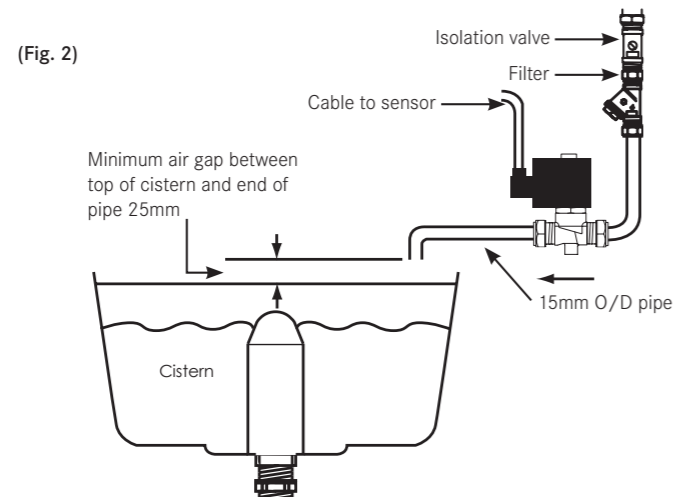

NOTE : The detection area is an approximation and will vary from site to site, Fig.3 is designed to be a guide only.

Notes;

Step 4 : Mounting the Sensor

Standard Surface Mount Model

When positioning the sensor, care should be taken to ensure the sensor slots run parallel with the urinal(s). Remove the lid and place in a safe place. Select a convenient cable entry point on the box, then drill and fit an appropriate cable gland.

Drill and secure the sensor box base to the required position on the ceiling with suitable fittings, as shown in Fig.4. Fit one end of the valve cable (not supplied) into the box base from the top, or via conduit, from the side, temporarily refit the Sensor lid.

Run cable back to Solenoid Valve, and wire into valve plug as described in Step 5.

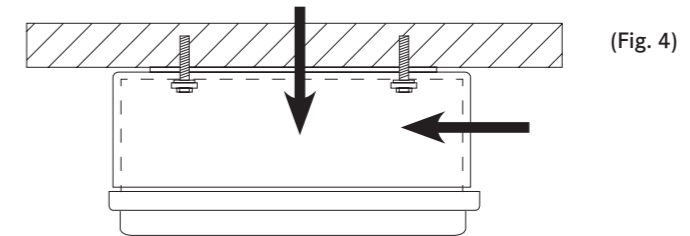

Downlighter Model

Ensuring that there are no mains cables etc. directly above the ceiling, drill or cut a 100mm diameter hole in the ceiling material. Insert the valve cable into the lid and secure.

Run cable back to Solenoid Valve, and wire into valve plug as described in Step 5. At this point, **DO NOT** fix downlighter into ceiling as you will need access to complete set up.

At this point, do not fix downlighter into the ceiling as you will need to access to complete set up.

IMPORTANT : Step.4 (from this point onwards) is to be completed AFTER Cistern Setup and Testing (Step.6)!

Whilst holding the 'A' arms in (as shown in Fig.5), push the sensor up into the hole. The 'B' arms will automatically click into position when the 'A' arms are pushed down on the upper/inner side of the ceiling.

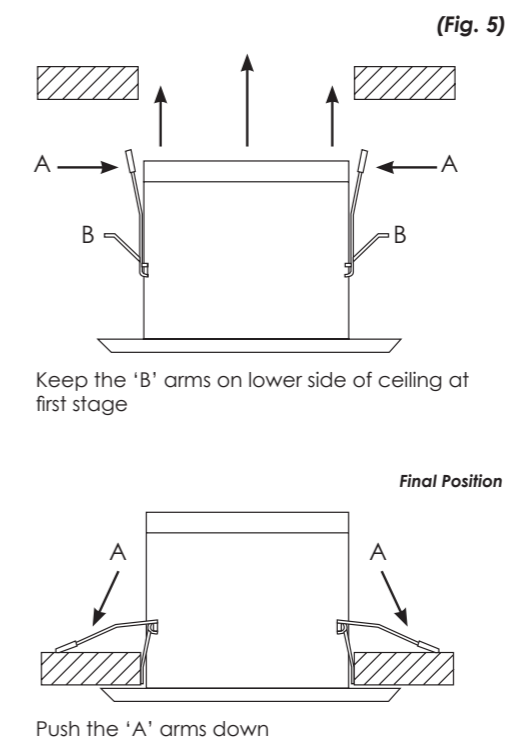

Step 5 : Wiring & Electrical Connections

Valve Connection

Fig.6 shows that the valve should be connected with 2 core 0.5mm diameter cable (not supplied). Trim the cable to the length required, taking care to connect the blue and brown cables correctly to the valve connector and PCB connector as per Fig.6. Do not connect to the sensor board at this stage.

Wiring must comply with Local and National regulations. Connection to the coil must be made via the supplied plug connector. The coil can be rotated through 360° to facilitate wiring.

Power Connection

The power supply required for the sensor is 6 volts DC which can either be supplied by a battery or a DVS mains Power Supply Unit (PSU).

Battery Version

The battery supplied is a standard 2CR5 lithium battery. Connection to the board is via a flexible 2 pin connector, great care must be taken to connect it in the correct polarity (see Fig.6).

Caution must be exercised with Lithium type batteries:

1. DO NOT attempt to recharge
2. DO NOT expose to naked flames
3. DO NOT 'short circuit' battery
4. DO dispose of battery according to local regulations

Mains Version Only

If a DVS power supply unit is used, a battery is not required and the output cable from the power supply is simply connected instead of the battery (see Fig.6).

Ensure the cable is housed safely within the sensor enclosure with a cable gland (not supplied).

A 1m length of 0.75mm 2 core flex is supplied with the PSU - this must not be extended.

The PSU should be located in a dry location, away from extremes of temperature and not exposed to dirt, dust or damp

Always connect the power via a **3 amp** fused spur. The product must be permanently connected to the supply, fitting a plug is not recommended. A suitable means of disconnection should be provided, in accordance with local electrical regulations. If the mains lead becomes damaged, the product should not be used. Contact DVS for replacement parts.

(Fig. 6)

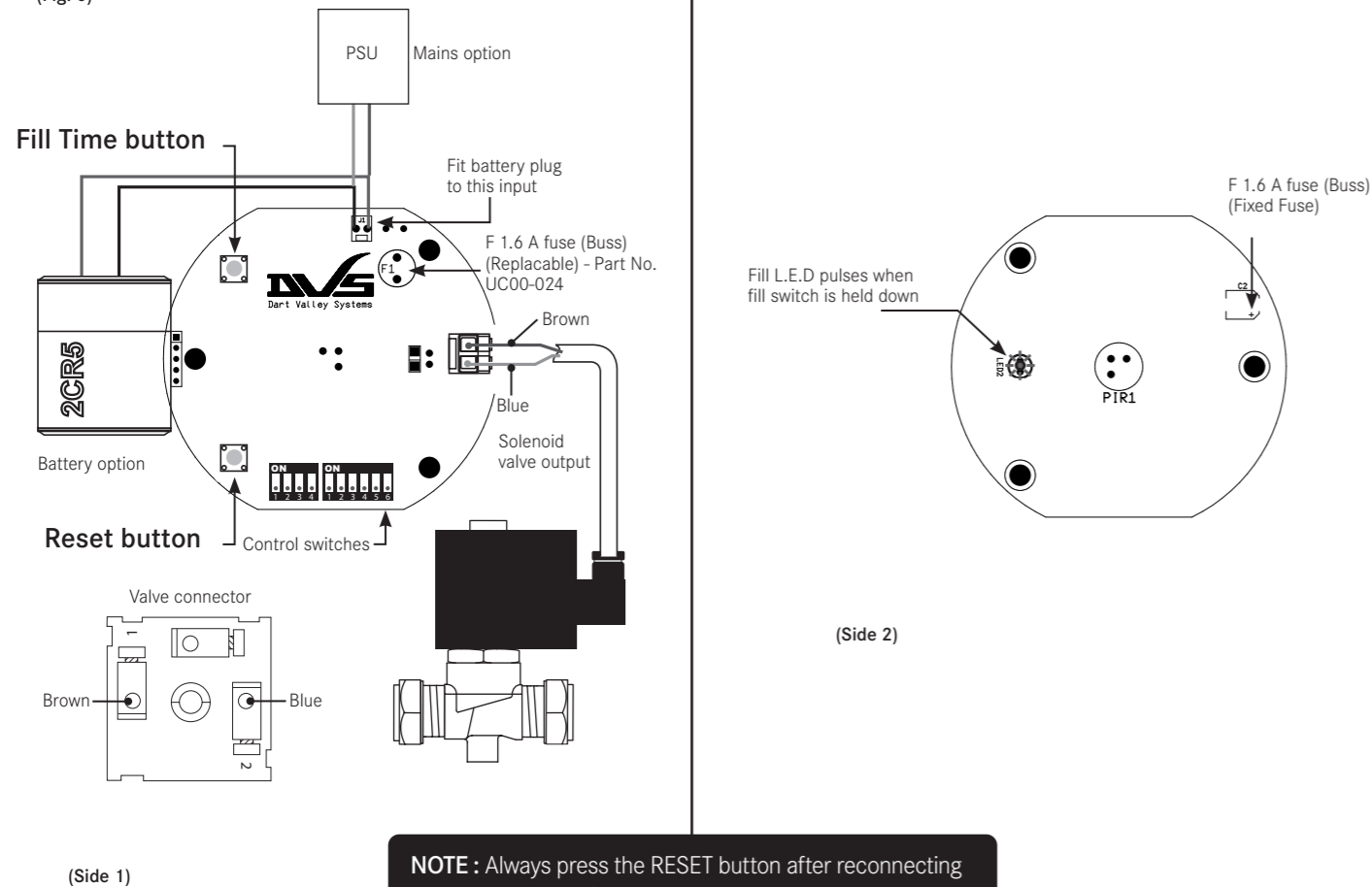

(Side 1)

(Side 2)

NOTE : Always press the RESET button after reconnecting the power to the PCB.

Step 6 : Flush Time Setup

Test Mode

When all control switches are in the OFF position the sensor defaults to test mode.

With the sensor wired to the solenoid valve, plug in the battery or power supply lead and briefly press the reset button. Wait 35 seconds, the valve will open for 5 seconds and then close. Once the valve has closed it will not open again for 35 seconds. If nothing happens, check connections, press reset button and try again.

The board has two sets of switches:

1 to 6 = **The fill and flush time:** The time it takes to fill and then flush the cistern from empty.

1 to 4 = **The delay time:** The period after the system completes a flush, before the next activation.

Cistern Fill Time - Using Button

To establish the correct Cistern fill time, you must start from an empty cistern. To do this, use the Fill Time button (Fig 6) to open the solenoid valve until the cistern flushes. Press and hold the Fill Button until the Red LED turns on, then press again to open the Solenoid valve. Once the cistern flushes, press the button again to close the valve. The Cistern is now ready to be timed.

The board will continue to run the preset defaults until the values have been setup. The values can be set individually at any time except whilst the unit is filling the cistern.

To set the Fill Time, keep the Fill time button pressed down until the Fill LED lights up, then press the Fill time button again to open the solenoid valve. When the cistern has filled and flushed, press the Fill time button again to close valve. If you do not press the Fill Switch again, the counting will stop after 15 minutes and the Fill Time set to 15 minutes.

NOTE - Fill Time Dip Switches **MUST** be in the **OFF** position if setting fill time with fill time button.

Cistern Fill Time - Using Switches

Once the valve is open and filling the cistern, wait for it to start flushing and then close the valve in the same way you opened it, but again- reverse the polarity.

When the cistern is completely empty open the valve again to start filling the cistern, but this time with a stopwatch time how long the cistern takes to fill and then flush, when flush is complete stop timing.

You will now have the fill time, the timings can be set by using switches 1 to 6 (see Fig.8 below).

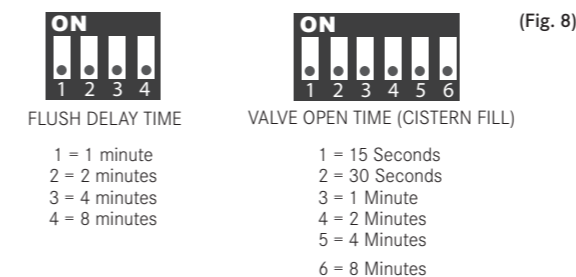

For example: If the desired fill time is 4 minutes and 45 seconds, you will need to put switches 1, 2 and 5 to the ON position (up) see Fig.9 below; 1 (15s) + 2 (30s) + 5 (4m) = 4 minutes & 45 seconds).

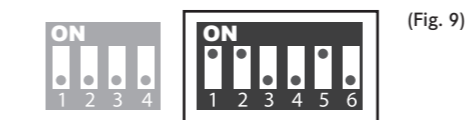

When you have set the fill time make sure that the solenoid valve cable is connected at both ends, and then connect the 6 volt battery, or, Power Supply Unit (PSU). Wait 35 seconds, then pass your hand in front of the sensor, the valve should then click open and start filling. Once the filling starts you can then add the delay time.

The delay time is set depending on site requirements, if you require a 15 minute interval between flushes, an example could be:

A 4 minute & 45 second fill time requires a 10 minute delay. Do this by using the switches 1 to 4 (see Fig.8), for a 10 minute delay you need to put switches 2 + 4 to ON (up) see Fig.10 below; 2 (2m) + 4 (8m) = 10 minutes.

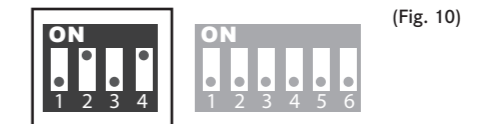

The setup is now complete wait for the system to flush and adjust timing if necessary, refit all covers and make sure all connections are secure.

An automatic "Janitor Flush" will occur every 12 hours to maintain hygiene, if the system remains unused.