

## Warranty & Support

### Warranty

The KWC DVS Temperature Blending Valve Adjuster is guaranteed for 5 years from purchase against defective material and assembly.

### Support

For technical support please visit our technical pages on our website at [www.dartvalley.co.uk](http://www.dartvalley.co.uk), contact us by email at: [kwcdvstechsupport@kwc.com](mailto:kwcdvstechsupport@kwc.com) or alternatively call us direct on 01803 529021.

## Notes

# KWC DVS

## Temperature Blending Valve Adjuster Installation & Operating Instructions

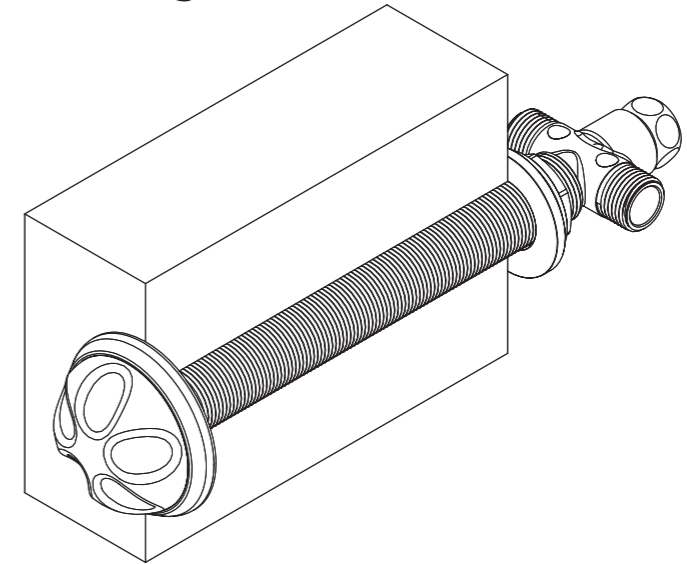

### Step 1 : Safety First

These instructions relate to the use of the **Temperature Blending Valve Adjuster** only, any external or 'add-on' parts will be supplied with separate instructions.

You must read these instructions thoroughly before attempting to install this product.

**IMPORTANT:** This product is not to be used as a thermostatic mixing valve. This temperature blending valve adjuster should be used in conjunction with an approved thermostatic mixing valve to prevent scalding.

**IMPORTANT :** Please read these instructions carefully and follow each stage in order!



### Step 2 : Parts

A typical system will comprise of the parts\* below:

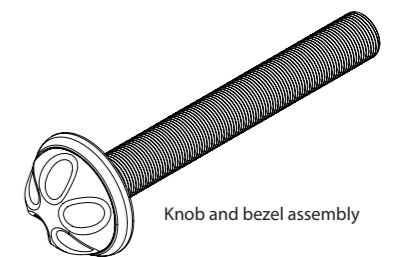

Knob and bezel assembly

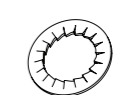

Serrated washer

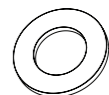

Washer



Flange nut

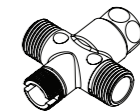

Blending valve

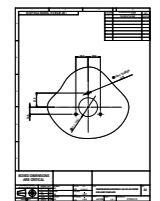

Drilling template

Instruction Manual x1

\*Not to scale

### Step 3 : Preparation

Overlay the drilling template and drill the required fixing holes.

Ensure dust and debris are removed from the surface before proceeding with the next stage.

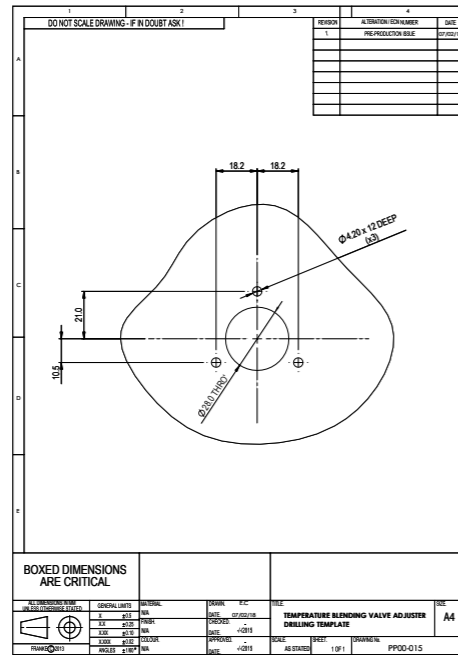

\*Drilling Template

### Step 4 : Adhesive

When fixing the knob and bezel assembly to the wall, KWC DVS recommend applying a high strength water resistant adhesive (not supplied) to the surface shown below.

The adhesive needs to be suitable for bonding stainless steel to the surface the adjuster is being fixed to.

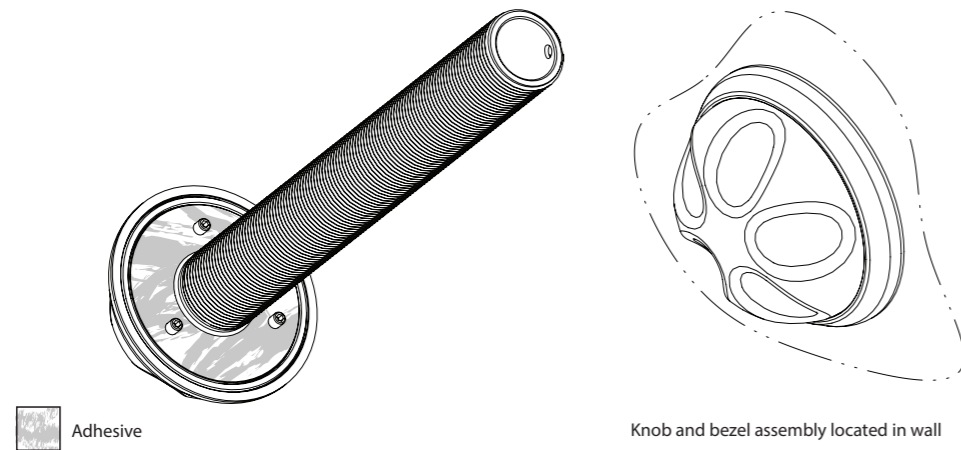

### Step 5 : Fixings

Assemble the washer, serrated washer and flange nut as illustrated below. Insert the blender valve and screw the retaining screw into position.

Ensure filters are installed inline prior to the inlets of the blending valve.

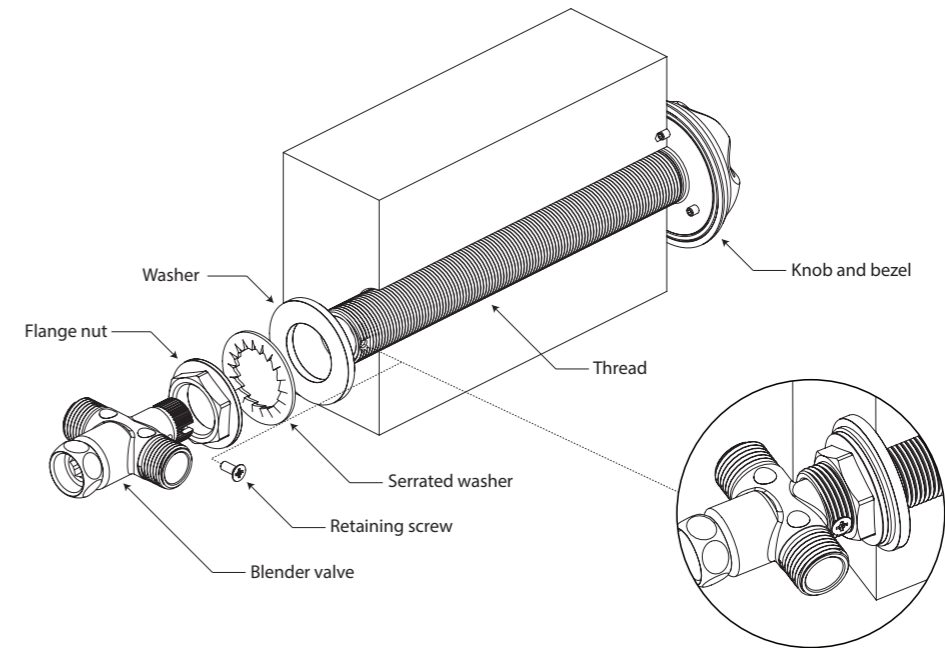

### Step 6 : Final Stage - Typical Installation

The temperature blending valve adjuster is typically used with KWC DVS electronic controls where user adjustment is required.

When plumbing into the blender valve, please take note of the colour coded stickers. The adjuster will not function correctly unless warm water is fed into the red inlet and cold water is fed into the blue inlet.

**NOTE:** Blending valve shown out of orientation for illustrative purposes only. Valve needs to be positioned horizontally as illustrated in **Stage 5**.

**IMPORTANT:** This product is not to be used as a thermostatic mixing valve. This temperature blending valve adjuster should be used in conjunction with an approved thermostatic mixing valve to prevent scalding.

**\*Not Supplied. Required for warm water output and to comply with new building regulations.**

