

Step 12 : Base options

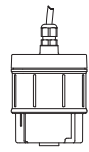

WC01 - 002
Flushvalve replacement body

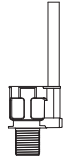

WC01 - 012
Flushvalve with in-built overflow (base only)
- 1 1/2" base

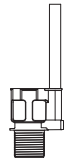

WC01 - 013
Flushvalve with in-built overflow (base only)
- 2" base



WC01 - 015
Flushvalve with in-built overflow (base only)
- Grohe fitting base

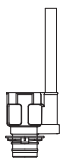

WC01 - 014
Flushvalve with in-built overflow (base only)
- Geberit fitting base

*Drawings not to scale

Warranty, support and end of life disposal

Warranty

The Flushvalve WC Flushing System V2 kit is guaranteed for 2 years from purchase against defective material and assembly.

Support

For technical support please visit our technical pages on our website at www.dartvalley.co.uk or contact us by e-mail at techsupport@dartvalley.co.uk Alternatively, you can telephone us direct on 01803 529021 and our customer service team will be pleased to help you.

Disposal of electrical and electronic equipment

The use of this crossed out wheeled bin logo indicates that this product needs to be disposed of separately to any other household waste.



Within each of the European Union member countries, provisions have been made for the collection and recycling of unwanted electrical and electronic equipment. Outside of the EU it will be necessary to dispose of this product at your local community waste collection or recycling centre. In order to help preserve our environment we ask that you dispose of this product correctly. Please contact your local council for collection centre details.

Head Office

Dart Valley Systems Ltd
Kemings Close
Long Road
Paignton
Devon
UK
TQ4 7TW

Contact Details

t : +44 (0) 1803 529021
f : +44 (0) 1803 559016
e : techsupport@dartvalley.co.uk
w : www.dartvalley.co.uk



www.dartvalley.co.uk



Flushvalve WC Flushing System V2

Installation & Operating Instructions

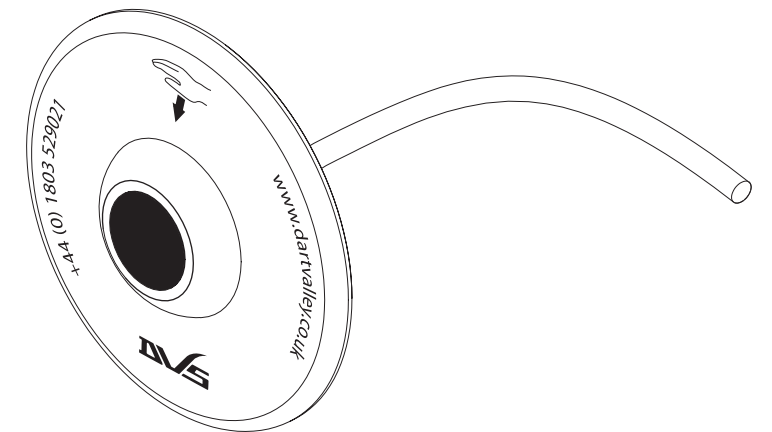
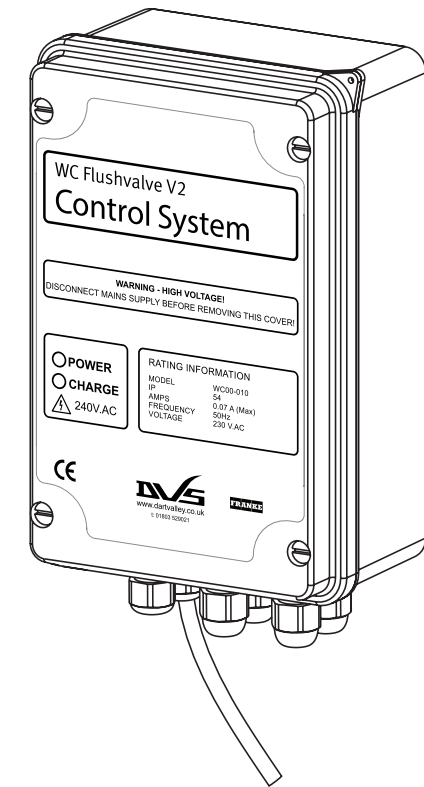
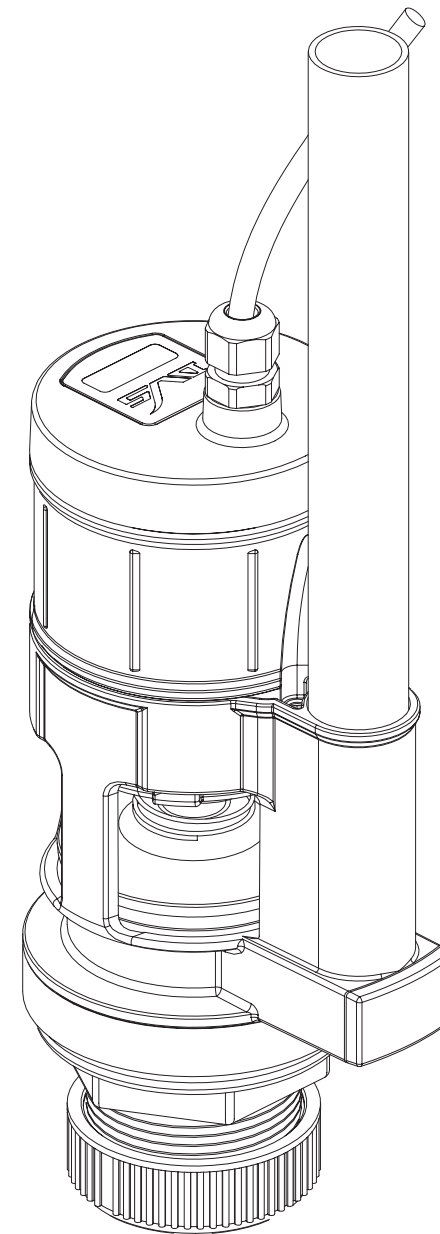

Dart Valley Systems | Kemings Close | Long Road | Paignton | Devon | TQ4 7TW | UK
T +44 (0)1803 529 021 | F +44(0)1803 559 016 | www.dartvalley.co.uk | techsupport@dartvalley.co.uk

Step 1 : Safety First

These instructions relate to the use of the Flushvalve WC Flushing System V2 only, any external or 'add-on' parts will be supplied with separate instructions.

It is recommended that the electrical part of the installation be carried out by a qualified electrician in accordance with the latest electrical regulations. It is also recommended that any plumbing is carried out by a qualified plumber.

This is a sophisticated electronic device which must be installed correctly to perform correctly.

If the appliance is used by persons (including children) with reduced physical, sensory or mental capabilities, or lack of experience and knowledge, they must be given adequate supervision or instruction concerning use of the appliance by a person responsible for their safety.

Children should be supervised to ensure that they do not play with the appliance.

IMPORTANT : Please read these instructions carefully and follow each stage in order!



Step 2 : Parts

Your kit will include the following items*:

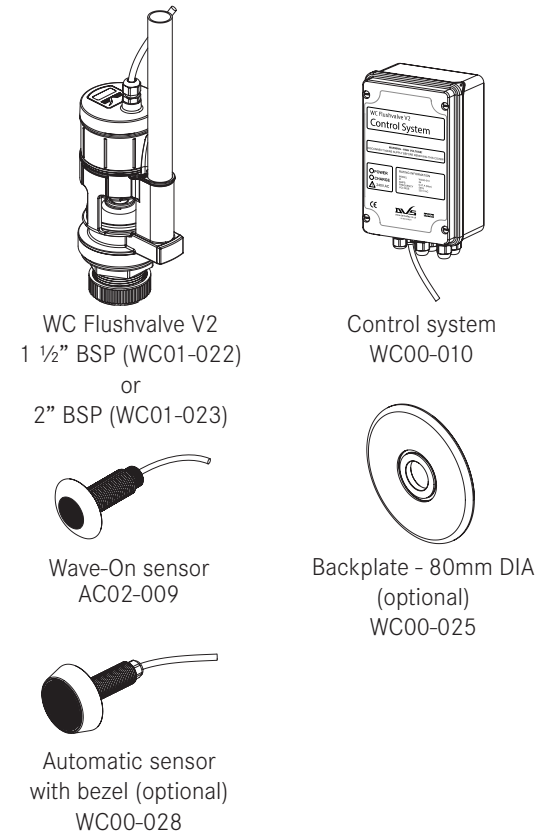

*not to scale

Instruction manual x1

Step 3 : Board layout - Inside lid

Key (Right):

1. Flush time and option setting switch
2. Power socket - In
3. Power socket - Out (For multiple installations)
4. Sensor input - Full flush
5. Sensor input - Half flush
6. Flushvalve input

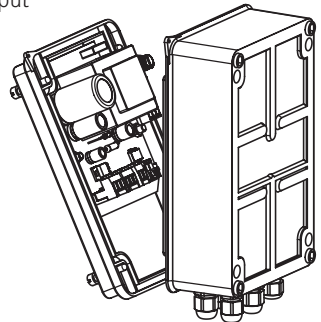

Safety

- **CAUTION!** 220-240V a.c.
- **NEVER** open the cover with the supply live.
- **DO NOT** extend cables.
- **DO NOT** leave badly fitted cables.
- **DO NOT** leave slack cables in the enclosure.
- **DO NOT** interfere with the mains flex.
- **DO** check all cables and connections.
- **Do** ask for advice if / when necessary

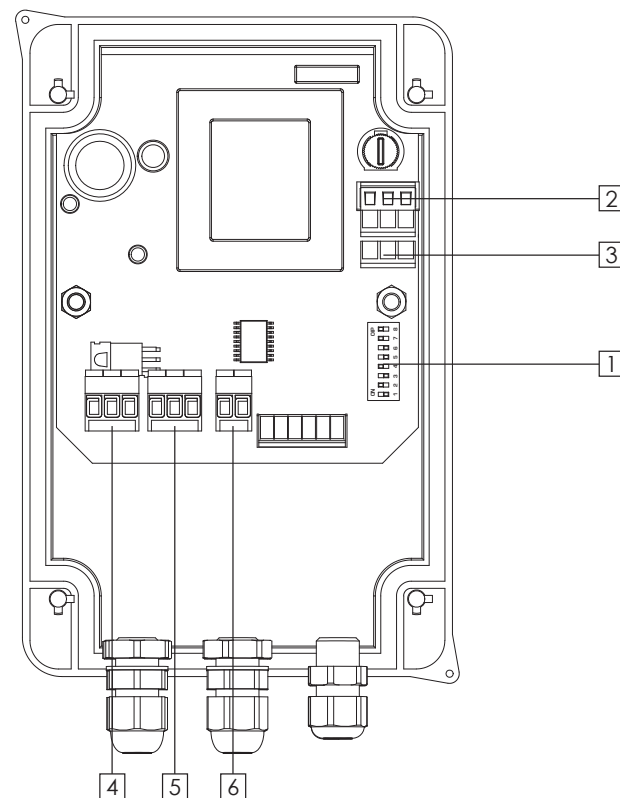

Step 10 : Time setting and basic operation

Safety

- **CAUTION!** 220-240V a.c.
- **NEVER** open the cover with the supply live.

DO NOT attempt to make adjustments until the power is isolated!

IMPORTANT: Adjustments will not be implemented unless the supply to the control system has been isolated.

The Green LED indicates that the system is powered ON.

Time settings

- Switch 1 = 3 second flush
- Switch 2 = 2 second flush
- Switch 3 = 1 second flush
- Switch 4 = 0.5 second flush
- Switch 5 = 0.25 second flush

The flushtime is the time set by the switches in the on position i.e. if switch 1 and 3 are set to ON the flushtime is set to 4 seconds. This is the default setting.

The flushtime time settings can be set from: 1 second to 6.75 seconds. Settings below 1 second will default to 1 second.

Operating the half sensor will result in a valve opening time of half the set time.

Option settings

- Switch 6 = Enables the purge function. When set to ON the system will purge if no operations have been carried out within the last 24 hours
- Switch 7 = Enables the lock out function. When set to ON the system will lock out if 4 operations are carried out within 15 minutes
- Switch 8 = Set to OFF for the standard sensor
- Switch 8 = Set to ON for the fully automatic sensor

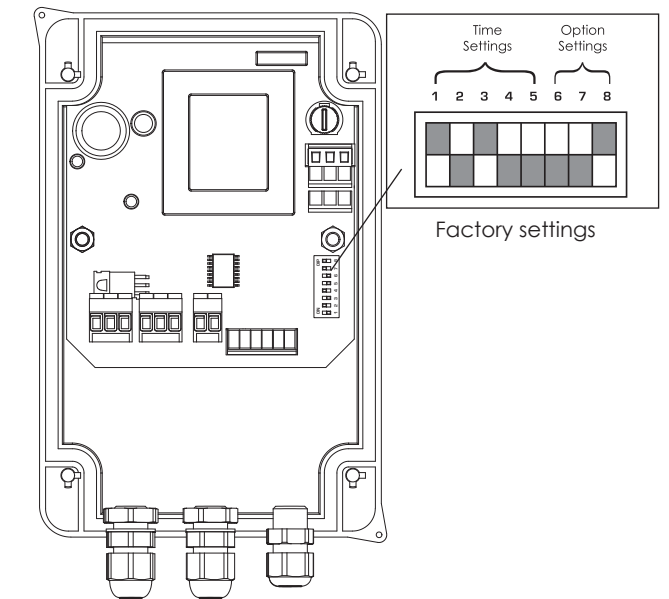

Step 11 : Final step - Start-up routine

When you first power up the system the Bicolour LED (Green - Normal/Red - Charge) will start up green and then change to red for the time set on the time select switches.

The red LED will turn off for a short time and then come on again for the initial charge period. When the red LED turns off for the second time the system is ready for use.

When the red LED goes out the system is active and monitoring the sensor inputs.

Upon a signal from one of the inputs the valve will lift for the time set on the time adjuster, when the valve drops the red LED will come on for the charge period, again indicating that the system is charging.

No operation of the valve is possible while the red LED is ON. Once the red LED goes out the system is ready for use again.

You have now completed the installation and the Flushvalve WC flushing system is now ready to use.

IMPORTANT : When powering up, ensure there is no solid or reflective material obstructing the sensor. This will result in a continual red flashing charge light and the unit will not flush. To reset, turn the power off. Allow 30 seconds, then remove any obstruction. Turn the power back on and allow for the control box to run through its start-up routine.

Key:

1. Power LED
2. Charge LED

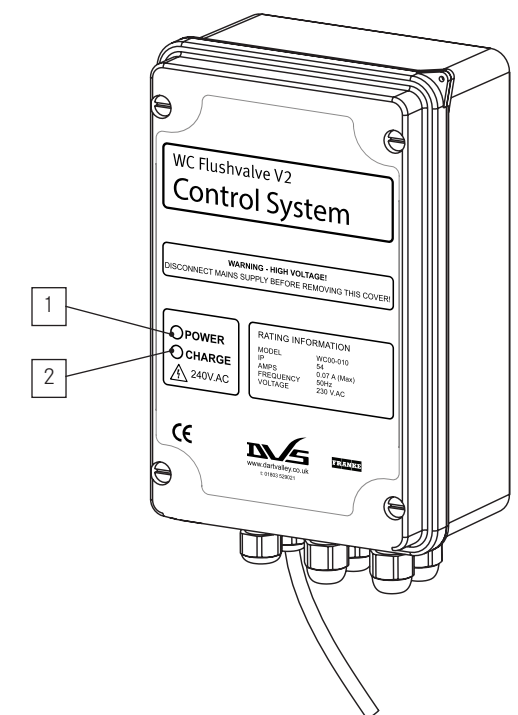

Step 8 : Flushvalve electrical connection

Connector plugs

The connector plugs can be disconnected from the mating sockets when wiring external equipment, double check positions with the plug orientations as they only fit one way!

Cable glands

Fit the Flushvalve cable through gland. Tighten until rubber touches the cable completely and then tighten with a further ½ turn (180°).

Cable connection

The Flushvalve cable should be trimmed to length and connected to the control box.

Connect the Blue wire to the Blue terminal, Brown wire to the Brown terminal. Please check the cable is clean and dry before connection onto the PCB.

When each plug has been wired the cables can be pulled back through the cable glands, and the plug re-connected to the corresponding socket. Cables should not be left to tort or slack.

Key (Below):

1. Flushvalve cable
2. Flushvalve connector plug
3. Flushvalve input
4. Control box lid

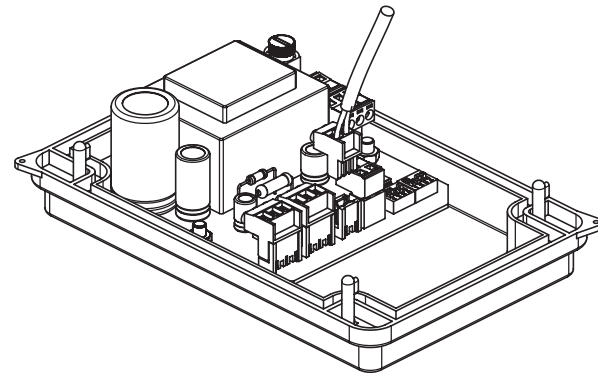

Safety

- **CAUTION!** 220-240V a.c.
- **NEVER** open the cover with the supply live.
- **DO NOT** extend cables.
- **DO NOT** leave badly fitted cables.
- **DO NOT** leave slack cables in the enclosure.
- **DO NOT** interfere with the mains flex.
- **DO** check all cables and connections.
- **DO** ask for advice if/when necessary.

Step 9 : Wave-On sensor fitting and connection

Care must be taken when positioning the sensor to ensure ease of use, and that general WC cubicle occupancy cannot accidentally trigger it.

The sensor needs to be fitted on a vertical surface less than 2 metres away from the control box through a 17-25mm pre-drilled hole, then secured with the nut, washer and bezel provided.

Alternatively the sensor can be mounted into the manual operating handle hole of an exposed cistern if required. Various sensor back plates and extensions are available from DVS for deep wall installations.

Cable connection

The control system has two connections for sensors, one for full-flush and the other half-flush. The sensor can be connected to either of two positions, or you can fit two sensors allowing the user the benefit of both options. If a second sensor is not ordered only one connector block is supplied.

Connect the sensor cable to the control box using the connector plug. Please check the cable is clean and dry before connection onto the PCB.

IMPORTANT: Do not attempt to modify or adjust the length of the sensor cable!

Key (Below):

1. Sensor
2. Bezel
3. Backplate
4. Mounting surface
5. Washer
6. Back nut

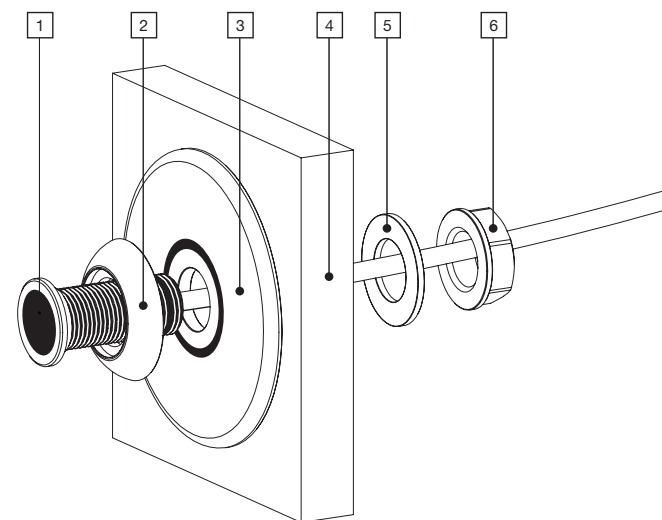

Step 4: Control system installation

Locating a suitable position

The control system should be located in a dry location, away from extremes of moisture and temperature and not exposed to dirt, dust or damp.

The unit should be accessible when required, but not within easy general reach of unauthorised persons. Secure access areas and duct spaces are recommended. The control system is not designed for direct surface mounting into washroom areas.

The routes that cables will take when connecting external equipment to the control system should also be planned at this stage.

Mounting the control system

Remove lid to expose four fixing locations around the back edge of the enclosure.

Drill through these marked areas away from the wall to avoid dust entering the enclosure, then hold control box in position against the wall and mark holes with a pencil. Remove box, drill and plug marked areas and fix the control unit with suitable fixings.

Securely mount the control system in a vertical orientation (cables exiting bottom) in an accessible location, no more than 2 metres from the valve and sensor.

Note: The standard cable length to the flushvalve is 2 metres and the sensor is 3 metres. Any other lengths are special order.

Connector plugs

The connector plugs can be disconnected from the mating sockets when wiring external equipment, double check positions with the plug orientations as they only fit one way!

Cable glands

Always fit cables through the glands provided. Tighten until rubber touches the cable completely and then tighten with a further ½ turn (180°).

Electrical cable connection

A 1.5 metre length of 0.75mm 3 core flex is supplied with the control box - this must not be extended.

Always connect the power via a 3 amp fused spur and ensure all cable glands are tight. A suitable means of disconnection should be provided, in accordance with local electrical regulations.

If the mains lead becomes damaged, the product should not be used. Contact DVS for replacement parts.

Typical Installation

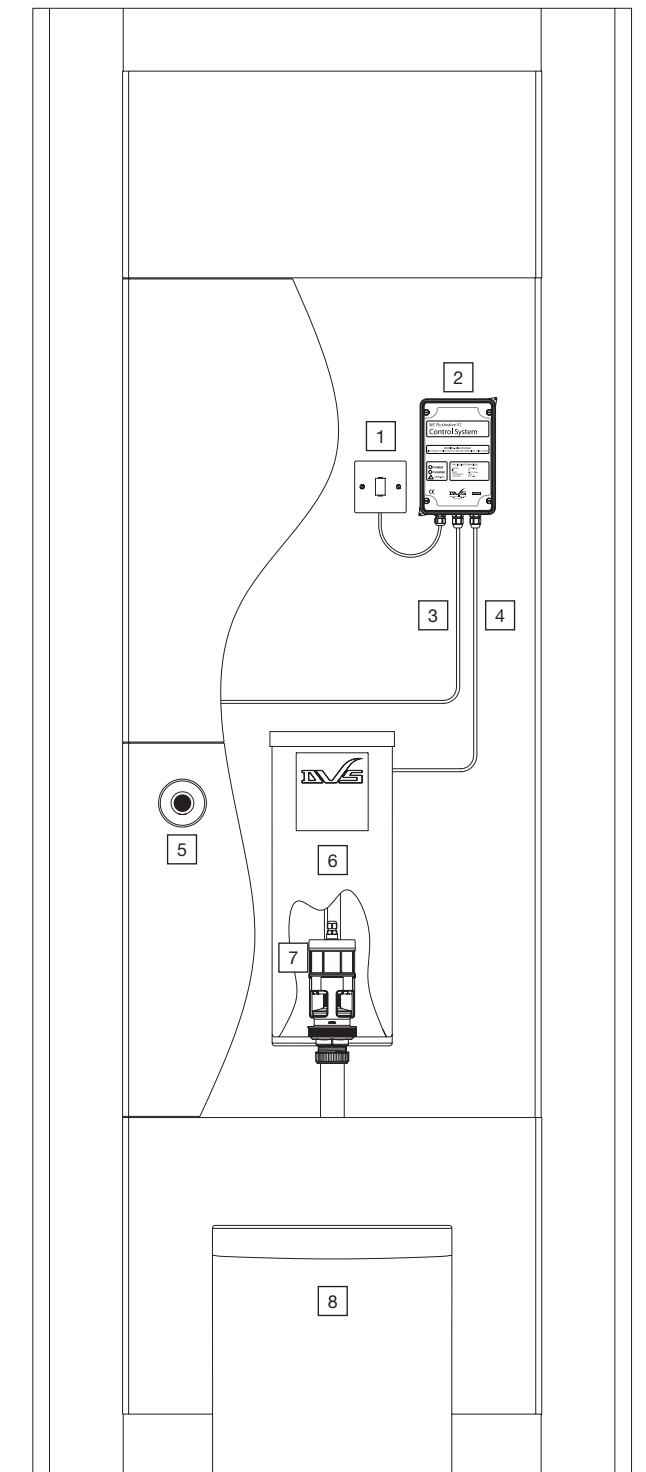

Key (Above):

1. 3 amp fused spur
2. Control system
3. Cable to sensor
4. Cable to Flushvalve
5. Sensor with backplate
6. Concealed cistern
7. Flushvalve in cistern
8. WC pan

Step 5 : Multiple Installations (optional)

A maximum of 4 control boxes can be wired together to share power from one 3 amp fused spur (see Fig 2).

Cable glands

On multiple installations you will need to fit an extra cable gland. Remove the blanking grommet on the bottom of the control box and fit the extra gland required.

Fit cable through gland. Tighten until rubber touches the cable completely and then tighten with a further ½ turn (180°).

Electrical connection

Using the power IN and power OUT sockets on the control board it is possible to daisy chain the control boxes together to share power.

A 1.5 metre length of 0.75mm 3 core flex is supplied with the control box - this must not be extended.

The lead should be prepared so that the earth conductor is longer than the live and neutral conductors, to ensure that the earth conductor remains connected should the lead be moved. The conductor ends should be stripped to 6mm and the use of insulated ferrules is recommended, the stranded ends must not be allowed to extend out of the terminals and the insulation must not be clamped.

Check for stray strands. If the mains lead becomes damaged, the product should not be used. Contact DVS for replacement parts.

A suitable means of disconnection should be provided, in accordance with local electrical regulations.

Safety

- **CAUTION!** 220-240V a.c.
- **NEVER** open the cover with the supply live.

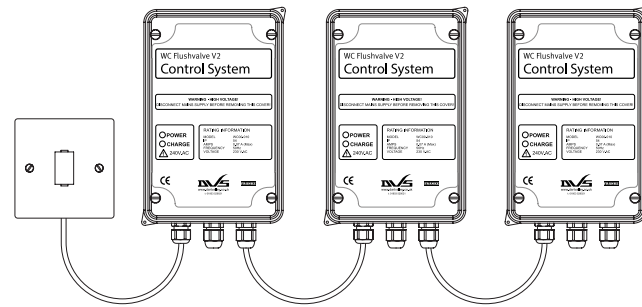

Step 6 : Valve Installation

Make sure the inside of the cistern is clean- removing any debris and ensuring the area around the seals are clean. Put some joint tape around the threads of the flushvalve and then fit the rubber seal provided.

Install the flushvalve into the cistern and secure with the back nut provided and then reconnect the existing flush pipe. Trim the overflow pipe so it is at least 20mm below the cistern overflow outlet. Install the inlet valve as per the manufacturers instructions.

The new valve may be separated into two parts by holding the base and twisting the upper body anti-clockwise for cleaning or de-scaling if required. However, ensure that the piston, spring and overflow pipe are replaced and secured correctly.

Route and secure the valve cable to a convenient position for the control box, i.e. within 2 metres.

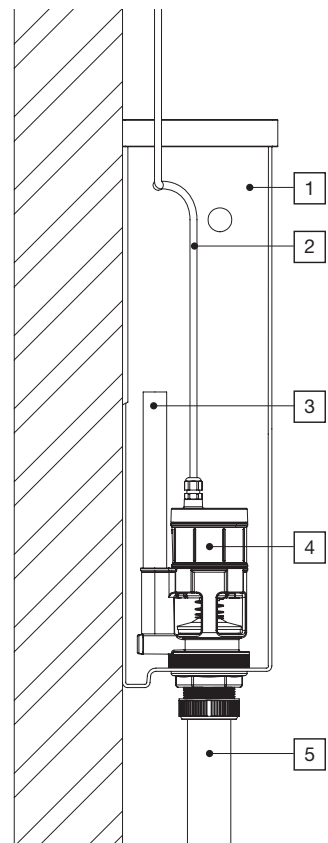

Key (left)

1. Cistern
2. Cable to control system
3. Overflow pipe
4. Flushvalve
5. Flushpipe

Step 7 : Water level

Once the Flushvalve is installed re-connect the water supply and ensure that the cistern fills correctly and that there are no leaks.

Maximum water level

The maximum water level must be below the top of the overflow pipe. This is usually controlled by an inlet valve operated by a float.

It is recommended that the maximum water level is set up now at this stage.

Minimum water level - IMPORTANT

The minimum water level after flush cycle finishes must be 5mm above the Flushvalve window. It is very important that the minimum water level does not fall below this level.

If the level falls below this point the valve operation will be more audible and you also risk damaging the valve.

The minimum water level is controlled by the flush time on the control system (covered later in section 9 of these instructions).

It is recommended that tuning of the minimum water level is left until section 9 where flush time settings are explained in more detail.

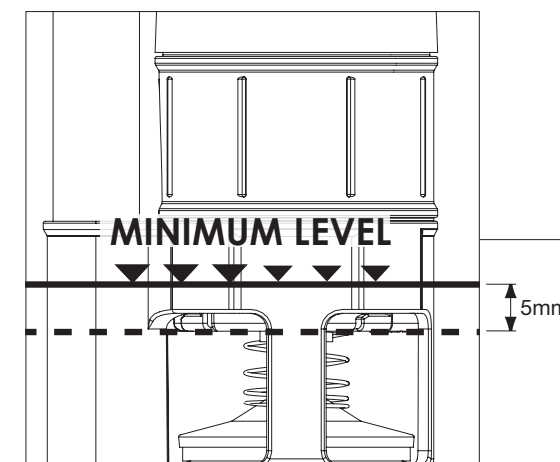

Key (right)

1. MAX Water level (controlled by float switch)
2. MIN Water level (controlled by flush time)
3. Top of Flushvalve window

