

Fault finding & General cleaning

1. SENSOR WILL NOT OPERATE AT ALL

- Check all electrical connections (see Fig 3 on page 3).
- Check fuse (Mains/PSU model only) max 3 amp fuse
- Voltage too low. Check tap input voltage (PSU output voltage - 6v DC).
- Voltage too low. Replacement battery code AT00-026 (CRP2 or DL223A) Lithium Cell only.
- Check / Clean all connectors (shown in Fig 3).
- Check for cable damage.
- For mains/PSU and battery models, disconnect for 1 minute then reconnect and allow sensor to recalibrate.
- Check water is turned on.
- Check the solenoid valve is fitted correctly.
- Check valve operation.
- Check for dirt or debris in the solenoid valve.
- Water pressure is too low / too high.

2. SENSOR OPERATES IN REVERSE

- (Water runs when hand is moved away from sensing area and stops when returned to sensing area)
- Reversed valve polarity (contact KWC DVS)

3. SENSOR OPERATES INTERMITTENTLY

- Clean sensor lens (with nonabrasive materials only).
- Shower may be installed too close to an R.F. interference source or direct sunlight.
- Water pressure too low for valve to operate reliably (minimum 1.0 BAR required) for standard solenoid valves.

- Voltage too low. Check tap input voltage (PSU output voltage - 6v DC).
- Voltage too low. Replace battery, CRP2 or DL223A Lithium Cell only.
- Disconnect power for 1 minute, then reconnect and allow the sensor to recalibrate.

General Cleaning

IMPORTANT: Do not use abrasive materials or cleaners. Only use soap and water or nonabrasive cleaners.

Valve Servicing

The valve will require periodical servicing and cleaning, please contact KWC DVS for servicing.

Do not attempt to dismantle the valve if you are unfamiliar with electronic solenoid valves.

Optional Parts

AC03-019	Standard Y-strainer - 15mm compression
AC17-004	Low pressure 0-1.0 Bar 6V 4mm solenoid valve
AT00-200	1m PSU cable extension
AT00-201	2m PSU cable extension

KWC DVS

Wall Mounted Tap Sensor Installation & Operating Instructions

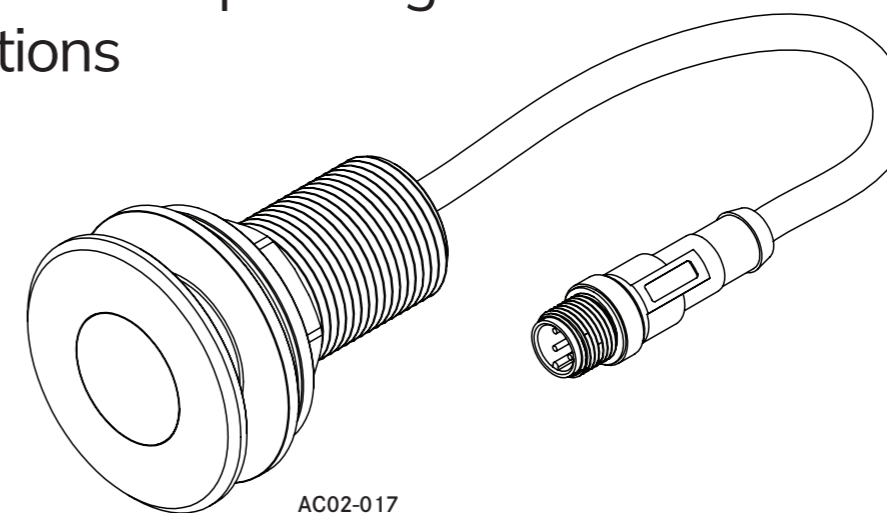

AC02-017

Warranty, Support & End of Life Disposal

Warranty

The tap sensor kit is guaranteed for 5 years from purchase against defective material and assembly.

The solenoid valve is guaranteed for 12 months, subject to water condition, however it is expected that the valve internals will operate efficiently for many years.

Support

For technical support please visit our technical pages on our website at www.dartvalley.co.uk or contact us by e-mail at kwcdvstechsupport@kwc.com. Alternatively, you can telephone us direct on 01803 529021 and our customer service team will be pleased to help you.

Disposal of electrical and electronic equipment

 The use of this crossed out wheeled bin logo indicates that this product needs to be disposed of separately to any other household waste.

Within each of the European Union member countries, provisions have been made for the collection and recycling of unwanted electrical and electronic equipment. Outside of the EU it will be necessary to dispose of this product at your local community waste collection or recycling centre. In order to help preserve our environment we ask that you dispose of this product correctly. Please contact your local council for collection centre details.

Disposal of waste batteries

 The use of this crossed out wheeled bin logo indicates that the battery needs to be disposed of separately to any other household waste.

Within each of the European Union member countries, provisions have been made for the collection and recycling of waste batteries. Outside of the EU it will be necessary to dispose of this at your local community waste collection or recycling centre.

In order to help preserve our environment we ask that you dispose of this battery correctly. Please contact your local council for collection centre details

Step 1 : Safety first

These instructions relate to the use of the **Wall Mounted Tap Sensor** only, any external or 'add-on' parts will be supplied with separate instructions.

Appropriate personal protective equipment must be worn when installing, calibrating and commissioning this product.

It is recommended that the electrical part of the installation be carried out by a qualified electrician in accordance with the latest electrical regulations. It is also recommended that any plumbing is carried out by a qualified plumber.

This is a sophisticated electronic device which must be installed correctly to perform correctly.

If the appliance is used by persons (including children) with reduced physical, sensory or mental capabilities, or lack of experience and knowledge, they must be given adequate supervision or instruction concerning use of the appliance by a person responsible for their safety. Children should be supervised to ensure that they do not play with the appliance.



IMPORTANT: Please read these instructions carefully and follow each stage in order!

Step 2 : Parts

Your kit will comprise the following parts*:

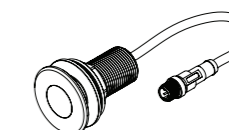

Sensor
AC02-017

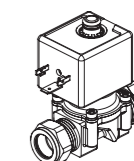

Solenoid Valve
AC17-006

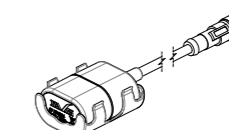

Battery Box
AT00-024

or

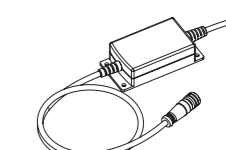

Power Supply
AT00-029

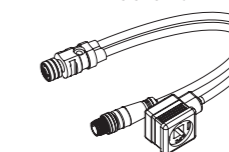

Y Splitter Lead
AT00-202

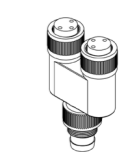

Optional Y Distributor
AT00-212

Instruction Manual (x1)

*Not to scale

Step 3 : Typical Installation

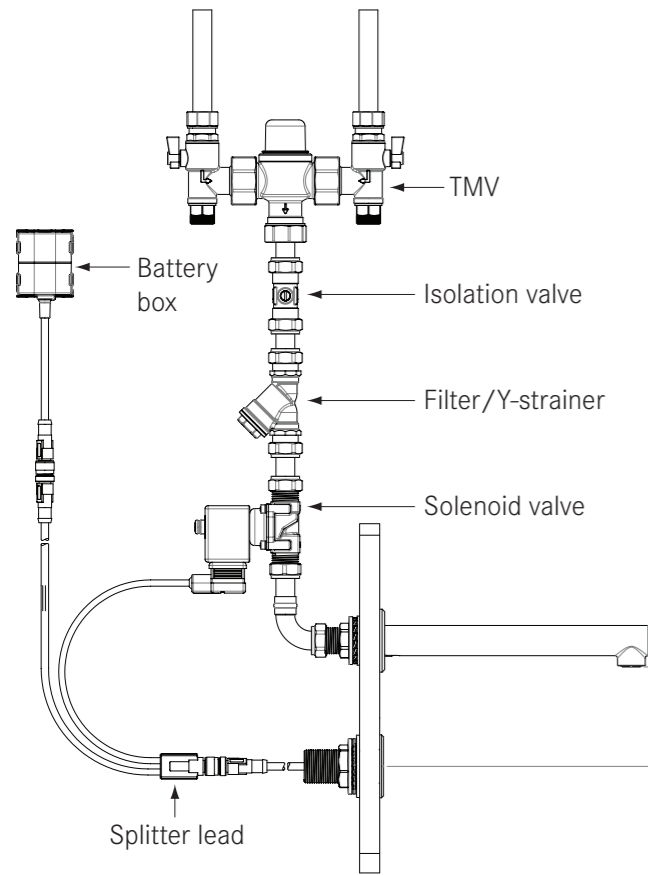

Caution! For mains powered setups you must use the KWC DVS AT00-029 power supply unit. Do not attempt to use any other device or power supply system.

Ensure the battery box or power supply is left disconnected at this stage.

A maximum of three taps should be run from a single PSU.

Note for Multiple Installation kits:
2 Station Kits contain one AT00-036.
3 Station Kits contain two AT00-036's and one AT00-033 extension.

The detectable range of the sensor will be default to approx 60mm, however, the range is fully adjustable via the Handheld Programmer (available separately).

The minimum recommended distance from the underside of the spout to the centre of the sensor is approximately 60mm. This may vary if there is excessive reflection which can be caused by bright surfaces such as chromed wastes and / or bright lights mounted directly above the basin.

60mm recommended minimum

Fig 1

Multiple Installation

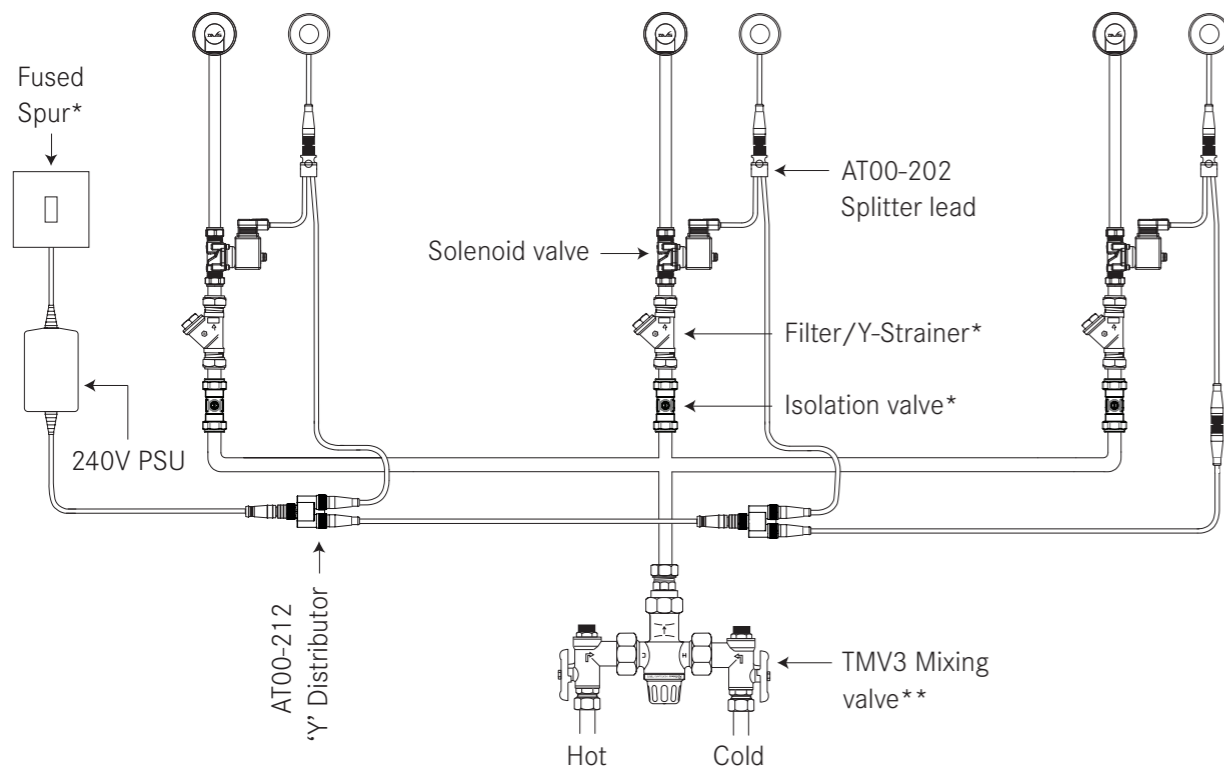

Fig 2

*Not supplied. Can be ordered separately from KWC DVS.

**Not supplied. Required for warm water output and to comply to current water byelaws. Can be ordered separately from KWC DVS.

Pressure Notes: All automatic taps come standard with a 12.7mm solenoid valve which requires 1 BAR to operate. If the water pressure is less than 1 BAR, low pressure valves should be fitted - To contact KWC DVS technical support please refer to page 4.

Step 4 : Preperation

You must read these instructions thoroughly before attempting to install this tap. First check the solenoid valve supplied is suitable for the sites water pressure and conditions.

The standard valve requires 1-10 BAR water pressure and 5-55°C water temperature. If your water pressure is low (0.5 bar or less) low pressure valves should be obtained from your supplier. See Section 8: General Cleaning.

Pre-Fitting

First turn off the water supply. If possible select an upright position for the solenoid valve. Check correct water flow direction on installation of the solenoid valve. The fitting of an isolator and Y-strainer (AC03-019) prior to the solenoid valve is highly recommended (not supplied).

All infra-red taps can be affected by highly reflective surfaces. Avoid mounting too close to reflective surfaces or direct sunlight.

IMPORTANT : Before installing the tap itself, please be aware that wherever possible you must use the anti-rotation pins supplied for the tap base. Non-use of the anti-rotation pins in suitable areas can result in void of warranty.

Step 6 : Plug & Socket Connections

Caution! Mount the battery box or power supply with care, in a dry location, away from extremes in temperature and not exposed to dirt, dust or damp.

Ensure the battery box or power supply is left disconnected at this stage.

Electrical cable connection for Power Supply Unit (PSU)

It is recommended that the electrical part of the installation be carried out by a qualified electrician in accordance with the latest electrical regulations.

A 1m length of 0.5mm 2 core flex is supplied with the PSU - this must not be extended.

Each PSU should be connected separately via a **3 amp** fused spur. The PSU must be permanently connected to the supply. A suitable means of disconnection should be provided, in accordance with local electrical regulations. If the mains lead becomes damaged, the product should not be used. Contact KWC DVS for replacement parts.

NOTE: Incorrect fuses may void warranty.

Final Stage

Ensure all cable sockets and plug connections are clean and dry, then connect the tap to the split connector and solenoid valve firmly, ensuring all connections are secured tightly.

Step 5 : Installation

IMPORTANT: Plumbing compound should not be used to seal the pipework as oils leaching from the compound will prevent the solenoid valve from functioning correctly.

Cut the pipework with a plumbers pipe cutter, remove sharp edges and burrs. The diaphragm in the solenoid valve will be damaged by oil, grease and debris. The valve should be used on oil free pipe work only.

To prevent long term contamination the pipework must be thoroughly purged prior to fitting the solenoid valve.

Fit the isolator, Y-strainer and solenoid valve and ensure pipes are fully engaged in joints. Take care that the valve is fitted with the correct direction of flow as indicated on the valve. Be careful not to over tighten any joints.

For mixed water output, a TMV mixing valve is needed to safely control the hot water temperature. See Fig.1 'Standard Setup' for typical TMV installation.

Fit the automatic tap to the required position. Secure the tap with the nut and washers provided and connect pipework from the solenoid valve and turn on the water supply, checking for leaks.

Connect the battery pack or power supply unit to the remaining split connector socket.

Once the tap is powered up, allow 30 seconds for the sensor to calibrate. Attempting to operate the tap within this period may cause the sensor to false trigger. If false triggering occurs, disconnect power for 1 minute, then reconnect and allow the sensor to recalibrate.

Plug and Socket Connections

Optional extension cables (1 and 2 metre) are all available from the manufacturer to extend the low voltage output of the PSU to the vicinity of the taps. See Section 8: General Cleaning.

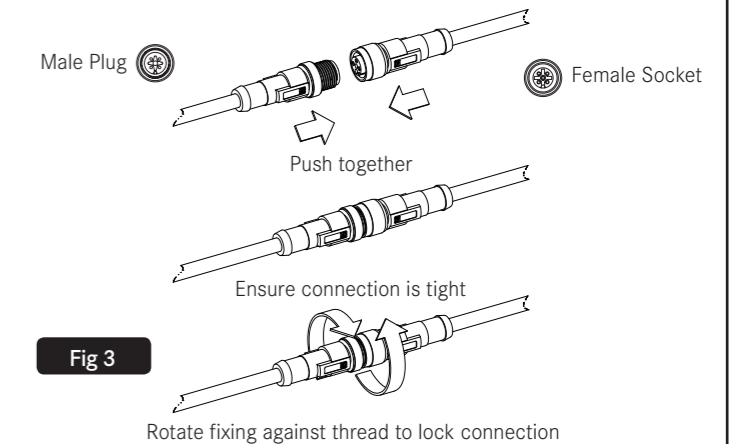

Fig 3